

An Innovative Option for Electrical Energy Conservation with a Step-Up DC-to-DC Power Converter Based Grid Tie Inverter

Zaber Hasan Mahmud¹, Dr. Md. Kamrul Hassan²

Department of Electrical & Electronic Engineering, American International University-Bangladesh^{1,2}
zaberhasan@gmail.com ; mdkamrul@aiub.edu

Abstract— *Researches on the Photovoltaic (PV) generation are extensively increasing, since it is considered as an essentially indefatigable and broadly available energy resources. Hence, the role of distributed generation i.e. solar energy based generation is increasingly being recognized as a supplement and an alternative to large conventional central power supply but mostly in off-grid areas rather than cities, whereas centralized economic system that solely depends on cities is hampered due to frequent energy deficiency. To extenuate these problems, this paper proposes an optimized design of single phase grid-tied PV system without storage which is employed with transformer-less power circuits. Most precisely this proposed design of Grid-Tie Inverter (GTI) results a pure sinusoidal wave of lower harmonics with higher efficiency which's mathematical expressions and results are simulated by using a software Power Sim.*

Keywords— Step-up DC-to-DC Converter, H-Bridge Inverter, T-LCL Filter, Super Diode.

I. INTRODUCTION

Energy is one of the critical inputs for economic development of any country. As people are much concerned with the fossil fuel exhaustion and the environmental problems caused by the conventional power generation, renewable energy sources are now widely used. Photovoltaic sources are used today in many applications such as battery charging, water pumping, home power supply, swimming-pool heating systems, satellite power systems etc. They have the advantages of being maintenance and pollution-free but their installation cost is high and in most applications, they require a power conditioner (dc/dc or dc/ac converter) for load interface. Since PV modules still have relatively low conversion efficiency, the overall system cost can be reduced using high efficiency power conditioners. The Photovoltaic Technology is also the most promising candidate for research and development for large-scale uses as the fabrication of less-costly photovoltaic devices becomes a reality. Because of constantly growing energy demand, grid connected photovoltaic (PV) systems are becoming more and more popular, and many countries have permitted, encouraged, and even funded this distributed-power-generation technology. The technology still has shortcomings such as high initial installation cost and low energy-conversion efficiency thus requiring continuous improvements of both cell and power inverter technologies [1]. In a conventional inverter, transformer is used to match the inverter output with the utility grid output [3]. But the only limitation here is that transformers are bulky, heavy weighted and costly equipment. Moreover transformer highly influences the enhancement of Total Harmonic Distortion (THD) in inverter. Therefore an improved way of synchronizing the PV Array output with the utility grid

using the transformer-less Grid Tie Inverter is introduced in this paper [2].

Here, a step-up dc-to-dc power converter (boost power converter) is recommended instead of transformer in order to achieve low THD as well as high efficiency. The boost power converter converts a large scale of voltage similar to the grid value but a single-stage boost converter requires a high duty cycle which is inconvenient for MOSFETs switching. Therefore, the DC-DC power conversion is employed through a dual-stage boost converter to obtain suitable duty cycle for MOSFETs switching. A voltage divider circuit is also used to synchronize the output frequency with the grid. Instead of using a conventional low-pass LC filter, a T-LCL filter is employed in the proposed inverter, which not only suppresses the harmonics contained in the inverter output but also maintains a constant output current for any type of load, and thus stabilizes the inverter output [4].

II. RESEARCH METHODOLOGY

Design of all important electrical equipments and power circuits are discussed below:

DESIGN OF SOLAR PANEL

The selected solar panel is of output voltage of 24 V at temperature 25 °C and irradiance 1000 W/m² under Standard Test Condition (STC).

Table-I shows the system parameters of photovoltaic module.

Table-I : System Parameters of PV Module

Parameter	Value
Short circuit Current (Ix)	5.57 A
Open Circuit Voltage (Vx)	50.9 V
Maximum Power (Pmax)	210 W
Characteristic Constant (b)	0.0773

DESIGN OF DUAL-STAGE STEP-UP DC-TO-DC CONVERTER

The design of a dual-stage DC-DC boost converter converts unregulated voltage of PV array to a fixed high level regulated voltage which is same as the grid value (312 V peak or 220 V rms in Bangladesh). Dual-stage converter provides a more symmetrical duty cycle, and reduces the voltage stress on the MOSFETs whereas a Single-stage converter provides higher duty cycle. The converted voltages are from 24 V DC to 86 V DC in the first-stage and 86 V DC to 312 V DC in the second-stage.

The design parameters of the first-and second- stage boost converters are listed in Table-II and Table-III respectively.

Table-III : System Parameters of First-Stage Boost Converter

Given input voltage (V_{in})	24 V
Desired average output Voltage (V_{out})	86 V
Minimum switching frequency of the converter (f_s)	20 KHz
Maximum inductor current ($I_{L,max}$)	260 A
ΔI_L Estimated inductor ripple current [1.75% of inductor current] (ΔI_L)	4.55 A
Desired output voltage ripple (0.05% of output voltage) ΔV_{out}	44 mV
Maximum output current (V_{out}/R) (I_{out})	4.3 A

DUTY CYCLE

Maximum Duty Cycle for First-stage,

$$D_{First-stage} = 1 - \frac{V_{in}}{V_{out}} = 1 - \frac{24}{86} = 0.72$$

Maximum Duty Cycle for First-stage,

$$D_{Second-stage} = 1 - \frac{V_{in}}{V_{out}} = 1 - \frac{86}{312} = 0.72$$

Table-II : System Parameters of Second-Stage Boost Converter

Parameter	Value
Given input voltage (V_{in})	86 V
Desired average output Voltage (V_{out})	312 V
Minimum switching frequency of the converter (f_s)	21 KHz
Maximum inductor current ($I_{L,max}$)	230 A
ΔI_L Estimated inductor ripple current [26% of inductor current] (ΔI_L)	60 A
Desired output voltage ripple [0.1% of output voltage] (ΔV_{out})	0.35 V
Maximum output current ($I_{out} = V_{out}/R$)	10.4 A

INDUCTOR AND CAPACITOR SELECTION

The following equations are used to calculate the values of inductance and capacitance in the Dual-stage DC-to-DC Converter.

The estimated inductor value for the First-stage is,

$$L_{1,Boost} = \frac{V_{in}(V_{out}-V_{in})}{\Delta I_L \times f_s \times V_{out}} = \frac{24(86-24)}{4.5 \times 20000 \times 86} = 190 \mu H$$

And the estimated inductor value for the Second-stage is,

DESIGN OF SUPER DIODE CIRCUIT

$$L_{2,Boost} = \frac{V_{in}(V_{out}-V_{in})}{\Delta I_L \times f_s \times V_{out}} = \frac{86(312-86)}{4.5 \times 21000 \times 86} = 50 \mu H$$

The estimated capacitor value for the First-stage is,

$$C_1 = \frac{I_{out} \times D}{f_s \times \Delta V_{out}} = \frac{4.3 \times 0.72}{20000 \times 0.044} = 3.5 \text{ mF}$$

And the estimated capacitor value for the Second-stage is,

$$C_1 = \frac{I_{out} \times D}{f_s \times \Delta V_{out}} = \frac{10.4 \times 0.72}{21000 \times 0.35} = 1 \text{ mF}$$

DC-TO-DC BOOST POWER CIRCUIT

The power converter which consists of two boost converters and two PWM gate pulses to drive the MOSFETs is shown in Fig.1.

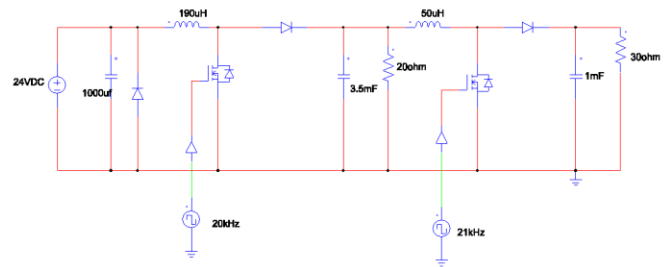

Fig.1. PSIM simulation circuit of the dual-stage boost converter using the designed circuit parameters

The output of the designed boost converter simulates using PSIM is shown in Fig.2. It indicates that the output of the first-stage is 86 V and second-stage is 312 V DC and which is later converted to 312 V AC (or 220 V rms) using an H-bridge inverter.

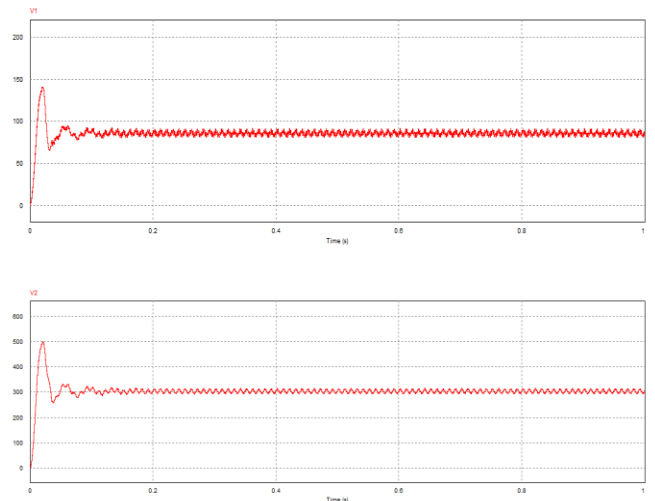

Fig.2. Boost converter output: V_a is the first-stage output (86 V) and V_b is the second-stage output (312 V)

This section provides the design of an AC-DC step down power converter. Here AC voltage sample is taken from grid which is converted into 312 V pulsating DC through full bridge rectifier

as shown in Fig.3. Then 312 V pulsating DC is converted into 7.07 V pulsating DC by implying voltage divider circuit which is shown in Fig.4. Here the super diode is a voltage divider circuit can be considered as dc equivalent to an ac step down transformer.

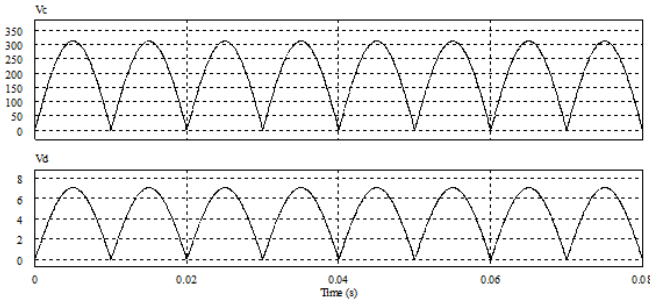

Fig.3. V_c is output of precision rectifier (312 V) and V_d is the output of super diode. (7.07 V)

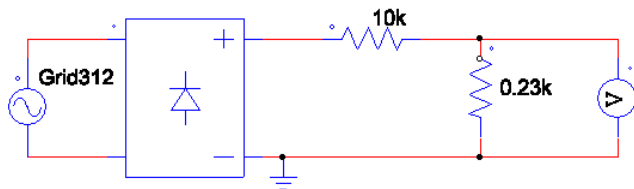

Fig.4. PSIM simulation circuit of the super diode

The super diode which consists of a rectifier circuit with two resistors is shown in Fig. 4. The output is 7.07 V (5 V rms) as shown in Fig. 3. In such a circuit, output is given to non inverting input portion of a comparator; which compare with the triangular wave in inverting portion of comparator. This part is assisted to match the voltage level with grid shown in Fig. 5. **TRANSFORMER-LESS GRID-TIE INVERTER**

The output voltage of a grid-tie inverter should maintain some fixed requirements so that it may provide power to grid utility. The requirements are given below:

1. The output voltage amplitude should equal as grid amplitude.
2. The frequency of inverter should be equal as grid frequency (50Hz in Bangladesh).
3. The phase of inverter should match with grid Synchronization Grid.

In a GTI function are divided into two major parts:

1. Grid synchronization,
2. Power transmitting.

For synchronizing frequency of inverter with the grid a sampled of sine wave is taken from grid. Afterward the sampled sine wave is rectified and passed through a voltage divider circuit and its output is compared with high frequency triangular wave to build SPWM which ensures same frequency [5]. To match same phase SPWM sets with phase-shift to zero. Then two sets of AND gate operation is performed with combination of SPWM and square wave to construct four individual signal for switching of inverter. The zero crossing detects when inverter output and

grid voltage both are in phase [6]. Once zero crossing is detected inverter and grid connection is tied via connector. After inverter and grid are connected mutually it starts to transmit power from PV array to grid. Now for protection purpose to avoid transmission of power when grid is down due to unavoidable circumstances a relay circuit is employed to trip inverter circuit from grid at this particular situation. A current transformer takes measurement if any fault is occurred at grid relay circuit will be trip and circuit breaker will isolated inverter from grid.

Fig.5. Schematic diagram of transformer-less grid-tie inverter in PSIM

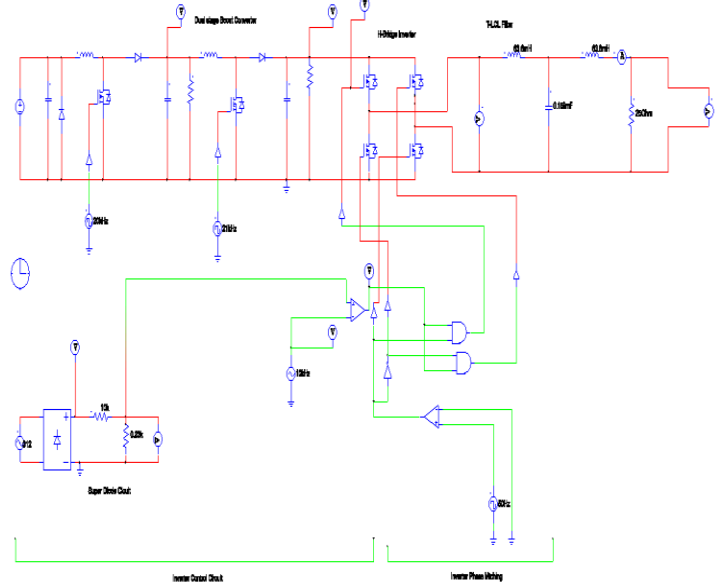

The proposed inverter circuit has employed four numbers of MOSFETs for switching purpose. The circuit is employed a DC-DC boost converter, the design of which is shown in section III, is used to step up the unregulated input voltage from 24V to regulated 312 V , which is finally converted to 312 V pure AC (220 V rms) applicable to grid by using inverter.

SWITCHING CONTROL

In conventional inverter design, Sinusoidal Pulse Width Modulation (SPWM) is generally used to get AC output. But in this article SPWM and square wave combination is used for inverter switching because this new technique reduces losses by reducing switching frequency. To accurately obey grid synchronization process the sine wave of the proposed design will be sampled from power grid by using buck power converter to step down the 220V grid voltage to 5V DC voltage [3-6]. As a result the frequency of GTI output will be as same as grid frequency. After that a high frequency triangular wave (10Hz) is compared with sampled sine wave by using comparator to build SPWM as shown in Fig. 4.3. The square wave is used as per grid frequency (50 Hz in Bangladesh) and is in same phase with SPWM. The square wave is also passed through a NOT gate which produces a signal 180° out of phase with the original signal. The inverter is required four sets of signal as it used four MOSFET in inverter circuit. Under this situation two sets of SPWM signal and two sets of AND gate operation is performed.

Eventually four sets of signal can be labeled into two groups. The first group consists of MOSFETs Q1 and Q4 while second group consists of MOSFETs Q2 and Q3. When Q4 is switched on SPWM is appeared at Q1 at that time Q2 and Q3 switches are off. Again when Q2 is turned on SPWM is appeared at Q3 and that time Q1 and Q4 switches are remaining off. For Q1 and Q4 pair positive voltage is emerged across the load. Moreover for Q2 and Q3 pair negative voltage is emerged across the load [2], [3-4]. The switches in each branch is operated alternatively so that they are not in same mode (ON /OFF) simultaneously .In practice they are both OFF for short period of time called blanking time, to avoid short circuiting. These bridges legs are switched such that the output voltage is shifted from one to another and hence the change in polarity occurs in voltage waveform. If the shift angle is zero, the output voltage is also zero and maximal when shift angle is π . The gate switching sequence is shown in Table- IV.

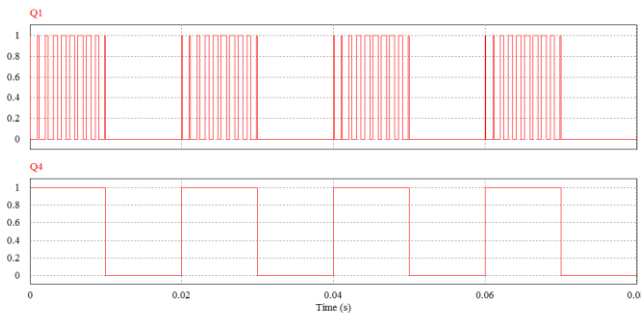

Fig.6. Switching signal from control circuit to MOSFETs Q1 and Q4

Q4

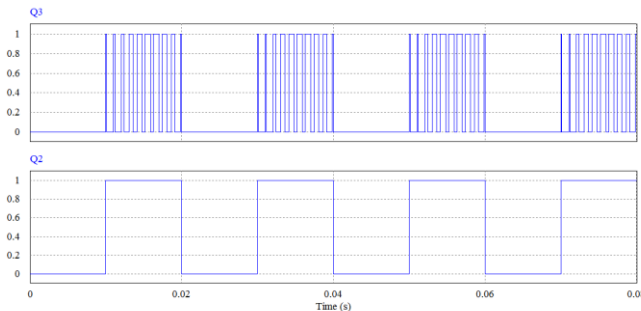

Fig.7. Switching signal from control circuit to MOSFETs Q3 and Q2

Table-IV : The gate switch sequence

Q1	Q2	Q3	Q4	V_{out}
ON	OFF	OFF	ON	$+V_s$
OFF	ON	ON	OFF	$-V_s$
ON	OFF	ON	OFF	0
OFF	ON	OFF	ON	0

FILTERING

T-LCL filter [5] is employed to reduce noise and maintain current in the output of GTI . In Fig.8, it is shown that T-LCL filter consists of two inductors L1 and L2 as well as a capacitor, C in T shape. The equations of the output current of the filter are found as [4]:

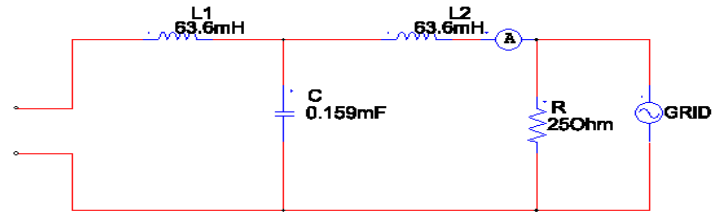

Fig.8. T-LCL Filter

$$I_2 \cong \frac{V_1}{Z_0} \left[1 - \frac{1}{Q} \frac{Z_2}{Z_0} \right]$$

Where V_1 is the input voltage, Z_2 is the load impedance, Q is the quality factor.

$$Q = \frac{\omega L}{r}$$

Here $\omega = 2\pi f$ the angular frequency, r is the internal resistance of the inductor and Z_0 is the characteristic impedance determined by the filter components, L and C :

$$Z = \sqrt{\frac{L}{C}}$$

When the internal resistance of the inductor is negligible or zero, the quality factor becomes infinity. Under this condition, the second term becomes zero, by giving the ideal condition.

$$I_2 \cong \frac{V_1}{Z_0}$$

From the above equation it is observed that the output of T-LCL filter is independent of load. Therefore, in the proposed inverter, a T-LCL impedance converter is applied as a filter circuit because it is not only capable in reduction of harmonic but also helpful to maintain constant current at the load.

The value of C and L of T-LCL filter (considering Butterworth type) is calculated using the condition of cut-off frequency of low pass filter.

$$Z_0 = X_c f = \frac{1}{2\pi f_c C}$$

In the proposed design, the cutoff frequency, $f_c = 50\text{Hz}$ and characteristic impedance is assumed as 20Ω . Therefore, the value of C and L is calculated as,

$$C = \frac{1}{2 \times \pi \times f_c \times R} = \frac{1}{2 \times \pi \times 50 \times 20} \approx 0.159\text{mF}$$

$$L = \frac{R}{2 \times \pi \times f_c} = \frac{20}{2 \times \pi \times 50} \approx 63.60\text{mH}$$

$$z = \sqrt{\frac{L}{C}} = \sqrt{\frac{63.6\text{mH}}{0.159\text{mF}}} \approx 20\Omega$$

$$f = \frac{1}{2\pi\sqrt{LC}} = 50\text{Hz}$$

II. RESULTS AND DISCUSSION

The simulated output voltage waveform that is non-sinusoidal distorted and it contains excessive harmonics which is shown in Fig.9. Thus, a low pass T-LCL filter is employed at the output terminal of the inverter to reduce the harmonics.

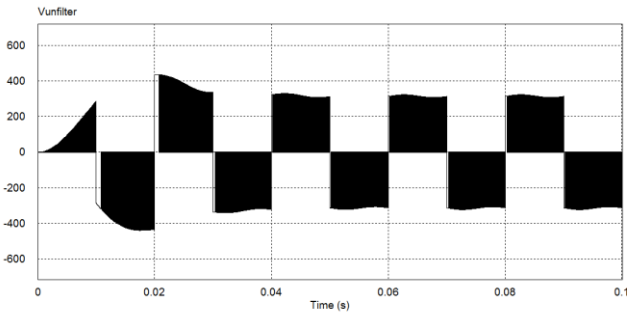

Fig.9. Output voltage waveform without filtering in PSIM
We obtained 220V (RMS), 50Hz pure sine wave output voltage and current waveform after filtering that is shown in Fig.10. and Fig.11. The proposed design helps the output voltage and current to become stable after single cycle.

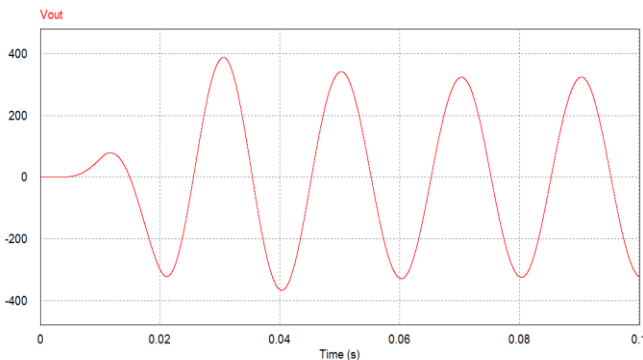

Fig.10. Output voltages after filtering in PSIM

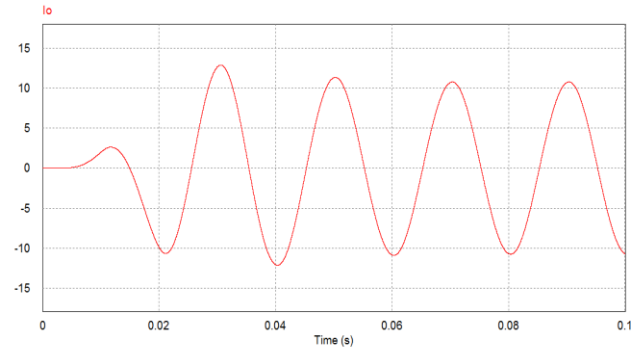

Fig.11. Output current after filtering in PSIM

Fig.12. presents the FFT analysis of output voltage unfiltered and filtered condition. The fast Fourier transform ensures that unfiltered inverter output has harmonics with mentioned value but filtered output has only fundamental harmonics which lies within 50 Hz and rest of harmonics are negligible. After filtering then output has low level of THD less than 0.1% because the proposed circuit is totally transformer less.

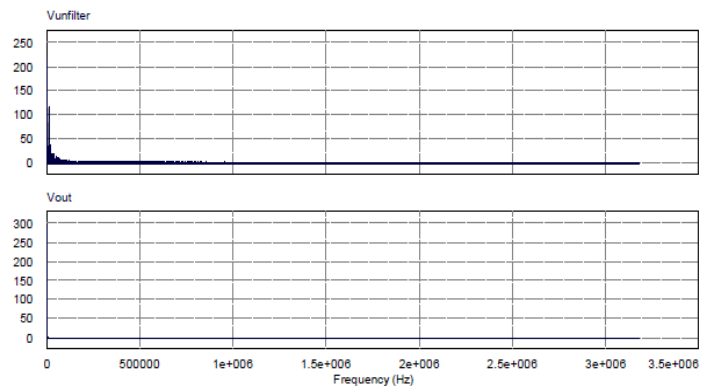

Fig.12. Output Voltage's FFT unfiltered and filtered condition in PSIM

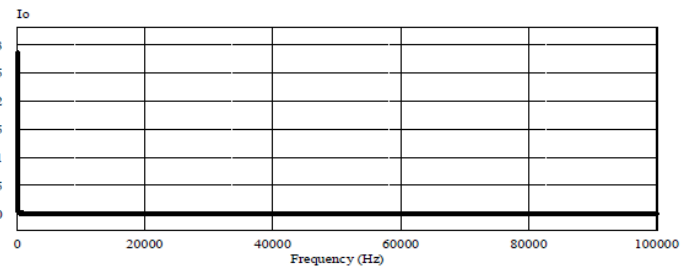

Fig.13. Output current's FFT in PSIM

The above Fig.13. represents the output currents with its FFT. Where again FFT demonstrates that fundamental harmonic component lies at 50 Hz and rest of them are eliminates.

INVERTER OUTPUT CURRENT

The peak value of the inverter output current is an important factor in designing the inverter stack size. The inverter current rating is normally determined by the filter impedance and the rated load impedance in a steady state. The output current should

maintained constant irrespective of load on the inverter and the output voltage is force to change [7].Therefore to maintain constant output current T-LCL filter is employed. It is found from filter equation output current of the inverter does not depend upon load.

$$I_2 \approx \frac{V_1}{Z_0} \left[1 - \frac{1}{Q_1} \frac{Z_2}{Z_0} \right]$$

In above equation at the time internal resistance is negligible or zero, the quality factor becomes infinity. Under this condition, the second term becomes zero, giving the ideal condition. Fig.14. shows load current versus load impedance of GTI for filter circuit.

$$I_2 \approx \frac{V_1}{Z_0}$$

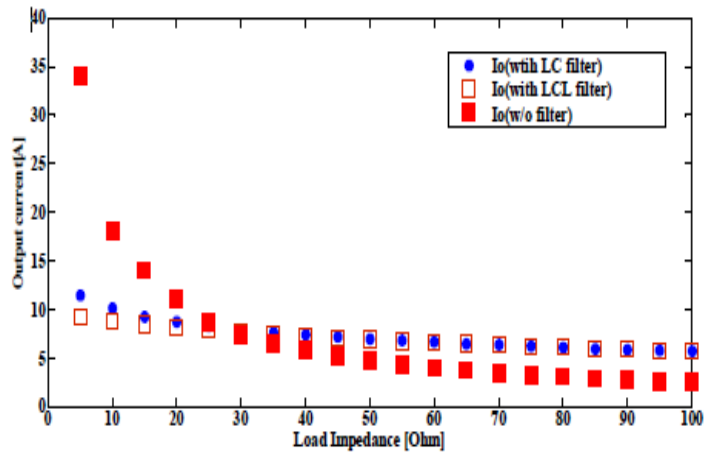

Fig.14. Output current vs. Load impedance

Here the load impedance was varied from 5Ω to 100Ω by considering characteristics impedance $Z_0 = 20 \Omega$ and current was measured from load without applying any filter circuit. Same procedure was applied for LC filter and T-LCL filter. It was observed that current across load without filter varying in a quite large range whereas in LC filter for varying load current changed in low scale and in T-LCL filter current is quite constant, which ensures longevity of appliances applied across the load of T-LCL filter and the graph is used data of Table-V.

Table-V : Inverter data for graphical representation

Load value	Pout [LCL filter]	Pin [LCL filter]	Io	Pin [LC filter]	Pout [LC filter]	$\eta\%$ [LC]	Io	Io /wo filter	$\eta\%$ [LCL]
5	651	706	11.42	427	456	93.64	9.24	34	92.2
10	1021	1070	10.1	766	799	95.86	8.75	18	95.42
15	1286	1331	9.26	1061	1101	96.36	8.41	14	96.61
20	1513	1563	8.7	1318	1366	96.5	8.11	11	96.85
25	1708	1771	8.26	1543	1602	96.31	7.85	8.7	96.7
30	1883	1956	7.92	1742	1812	96.13	7.62	7.42	96.27
35	2041	2125	7.63	1919	2002	95.68	7.4	6.48	96
40	2185	2281	7.39	2077	2174	95.53	7.2	5.75	95.79
45	2313	2424	7.17	2220	2331	95.23	7.03	5.17	95.42
50	2432	2558	6.97	2348	2475	94.86	6.86	4.69	95.07
55	2540	2682	6.79	2464	2607	94.51	6.69	4.3	94.7
60	2639	2798	6.63	2570	2730	94.13	6.54	3.97	94.31
65	2729	2905	6.47	2666	2844	93.74	6.41	3.68	93.94
70	2813	3008	6.39	2754	2950	93.35	6.27	3.43	93.51
75	2888	3102	6.2	2834	3049	92.94	6.14	3.22	93.1
80	2957	3191	6.08	2907	3142	92.52	6.03	3.02	92.66
85	3023	3277	5.94	2975	3230	92.1	5.91	2.86	92.24
90	3096	3373	5.86	3042	3319	91.65	5.81	2.71	91.78
95	3166	3466	5.77	3112	3412	91.2	5.71	2.57	91.34
100	3236	3561	5.68	3184	3509	90.73	5.64	2.45	90.87

INVERTER EFFICIENCY

Efficiency means ratio of output and input. The inverter efficiency is calculated through following formula.

$$\mu = \frac{P_{out}}{P_{in}} \times 100\%$$

And by varying load it was monitored that the efficiency of T-LCL filter was higher than the efficiency of LC filter. The efficiency versus load impedance for LC and T-LCL filter is shown in Fig.15. and the graph is used data of Table-V.

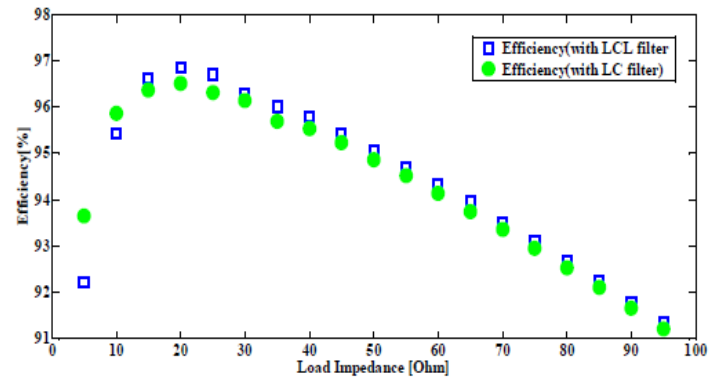

Fig.15. Efficiency vs. Load impedance

It is found that the proposed transformer-less GTI is highly efficient while it is transmitting power up to around 1000 W to 2400 W. At that time inverter efficiency is about 95% and in characteristic impedance the efficiency is 96.7% and when output RMS voltage is 220 V and load impedance is 30Ω inverter efficiency is 96.3%.

By analysis PV array system, the paper proposed a dual-stage intelligent PV system, which is similar to modular configuration topology. In an intelligent PV module instead of interconnection between modules they are interconnected with associated DC-DC converter. In this research, a dual stage Boost power converter is proposed instead of transformer which will be helped the whole system to make highly efficient, cost effective and light weighted and the whole system efficiency will be rise up to 96.3% with less than 0.01% THD. To make the inverter grid-tie a super diode circuit is proposed in this research proposal.

III. CONCLUSION AND FUTURE WORK

The proposed design can be turned into a fully functional grid-tie inverter for establishing connection between the source and the grid for transmitting power to an electrical grid. The simulation result using PSIM ensures that the frequency of the inverter output voltage is exactly 50 Hz with a magnitude of 220 V rms and is in phase with the grid voltage.

The hardware of the proposed grid-tie inverter would also be constructed with the help of a microcontroller and the experimental results would be compared with the ones obtained from the simulation. The simulation results would also be extended in order to expand the area of the research.

REFERENCES

- i. M. Gohul, T. Jayachandran, A. Mohamed Syed Ali, T.G.Raju, N. Santhosh Kumar, M.R. Saravanan "A New Design of Grid Tie Inverter for a Grid Interactive Solar Photovoltaic Power Generation—An Innovative Option for Energy Conservation & Security." *IJECT Vol. 2, Issue 3, Sept. 2011.*
- ii. N. Kasa and T. Iida "A transformer-less single phase inverter using a buck-boost type chopper circuit for photovoltaic power system" *Proc. ICPE '98, Seoul, Korea, pp.978-981, 1998*
- iii. Y. Beck, B. Bishara, D. Medini, "Connecting an alternative energy source to the power grid by a DSP controlled DC/AC inverter", *IEEE PES 2005 conference, Durban, South Africa, 11-15 July 2005.*
- iv. M. Liserre, F. Blaabjerg, S. Hansen, "Design and control of an LCL filter-based three-phase active rectifier", *IEEE Transactions on Industry Applications, vol. 41, no. 5, September/October 2005.*
- v. L. Chang, Y. Xue, G. Gou, "Design of a 400W single-phase buck-boost inverter for PV applications," *SESCI, pp. 1-6, June 2007.*
- vi. T. K. Kwang, S. Masri, "Single phase grid tie inverter for Photovoltaic application," *Proc. IEEE Sustainable Utilization and Development in Engineering and Technology Conf., pp. 23-28, November 2010.*
- vii. M. H. Rashid, *Power Electronics, Circuits, Devices, and Applications, 3rd Ed. New Delhi: Prentice-Hall of India Private Limited, 2007 pp.253-256.*