

# Four Wave Mixing Nonlinearity Effect in WDM Radio over Fiber System

Surbhi Jain<sup>1</sup>, Brintha Therese A.<sup>2</sup>

<sup>1</sup>Student, M.Tech Communication Engineering,

<sup>2</sup>Professor, SENSE Department,

<sup>1,2</sup>Vellore Institute of Technology, Chennai

surbhi.jain2013@vit.ac.in, abrinthatherese@vit.ac.in

**Abstract:** *The optical networks are fast and error free but due to some nonlinearity effects, its performance degrades. The performance of wavelength division multiplexing (WDM) in radio over fiber (RoF) systems is found to be strongly influenced by nonlinearity characteristics inside the fiber. In this paper, we have studied the effect of four wave mixing (FWM) as one of the influential factors in the WDM for RoF using Optisystem Software.*

**Keywords—** Radio over Fiber (RoF), Wavelength Division Multiplexing (WDM), Channel spacing, Power level, Nonlinearities, Four Wave Mixing (FWM)

## I. INTRODUCTION

The Radio over Fiber (RoF) application has increased its importance these days because it provides large capacity and low cost in deployment of cellular systems' base station. Radio over fiber (RoF) refers to a technology in which radio signal modulates light through an optical fiber. Here first at the central location, the broadband data signals are first modulated onto an optical carrier and then using optical fiber they are transported to the distant sites. These RF signals are then transmitted over small regions using microwave antennas through base stations.

When RoF transmits, there are little interactions between light waves and the material transferring them which thereby affect optical signals. Since their strength depends on the square or higher power of light intensity, the effects are commonly called as nonlinear effects. The commonly known effects are stimulated Raman scattering (SRS), stimulated Brillouin scattering (SBS), cross phase modulation (XPM), self-phase modulation (SPM) and four wave mixing (FWM).

When light reaches high intensities these effects become very strong but are found to be weak at low powers [1]. The output of lasers is converted to shorter wavelengths by doubling the frequency using nonlinear optical devices in Radio over Fiber applications.

The nonlinear effects are smaller in optical fibers which transmit a single optical channel. Wavelength division multiplexing (WDM) puts many narrowly spaced wavelengths into the same fiber [4] where they can interact with one another. The total power in the fiber gets multiplied; as a result the nonlinear effects become much larger. The block diagram of RoF WDM passive optical network is shown in Fig 1.

The RoF technology has many advantages compared to the electronic signal distribution like large bandwidth, easy

installation, easy maintenance, low attenuation and dynamic resource allocation.

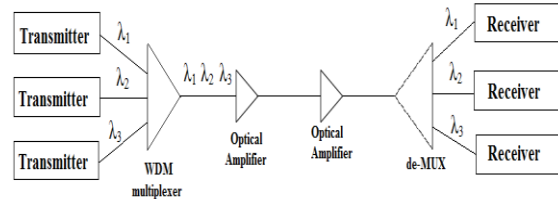

Fig. 1 Block Diagram for WDM system using multiple wavelength channels and optical amplifiers

This paper focuses on study of FWM effect in WDM. In this paper, we have investigated the performance of the WDM passive optical networks and effect of FWM non linearity. The paper is organized as follows: section II presents the Four Wave Mixing criteria. Section III presents simulation setup for WDM passive optical network. In section IV, we present the analysis and comparison result of the proposed architecture for three cases. Finally, section V contains the conclusion of the paper.

## II FOUR WAVE MIXING CRITERIA

FWM is a nonlinearity which occurs when the wavelength channels are very close to each other in WDM system. FWM does not depend on bit rate but the factors which sway the magnitude of the FWM products are channel spacing and fiber. The mixing occurs due to interference of original wavelength and the generated cross products. For N input wavelength, there will be M mixing products, given by [5]:

$$M = \frac{N^2}{2}(N-1)$$

For example, in a three channel system which suffers effect of FWM, nine sidebands are generated near the three original input wavelengths  $w_1$ ,  $w_2$  and  $w_3$  as shown in Fig 2(b). The additional products fall away from the original input wavelengths.



Fig 2 (a) Two input wavelengths  $w_1$   $w_2$  and the arising sidebands due to FWM

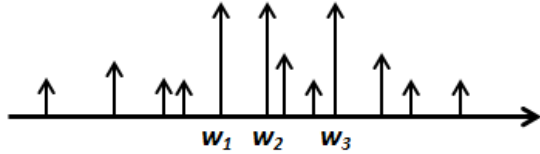

Fig 2 (b) Three input wavelengths  $w_1$   $w_2$ ,  $w_3$  and the arising sidebands due to FWM

Assuming there are two input wavelengths as  $w_1=1550$  nm and  $w_2=1551$  nm Then the interfering wavelengths generated around the original three wavelengths are  $2w_1 - w_2 = 2 \times 1550 - 1551 = 1549$  nm and  $2w_2 - w_1 = 2 \times 1551 - 1550 = 1552$  nm.

Similarly when the three input wavelengths are  $w_1=1550$  nm,  $w_2=1551$  nm, and  $w_3=1552$  nm. Then the interfering wavelengths generated around the original three wavelengths are  $w_1 + w_2 - w_3 = 1549$  nm,  $w_1 - w_2 + w_3 = 1551$  nm,  $w_2 + w_3 - w_1 = 1553$  nm,  $2w_1 - w_2 = 1549$  nm,  $2w_2 - w_1 = 1552$  nm,  $2w_3 - w_1 = 1554$  nm and  $2w_2 - w_3 = 1553$  nm.

## II. SIMULATION SETUP

Our simulation is performed and analyzed using OptiSystem software. The architecture for two channels with 2.5 GHz data rate is shown in Fig 4.

In this proposed architecture, the two signals with wavelength 1550nm and 1551nm are transmitted. The transmitter consists of continuous wave (CW) laser having 0 dBm power level. The output of which is modulated by modulator using a sine generator having frequency 2.4 GHz. The sine generator transmits modulated radio signal. The two signals are then combined using WDM multiplexer and launched through the optical fiber with distance of 25 km. The same analysis can also be performed for three channels as shown in Fig 5.

Fig 3(a). shows the output of optical fiber when two wavelengths are transmitted while fig 3(b) shows when three wavelengths are transmitted.

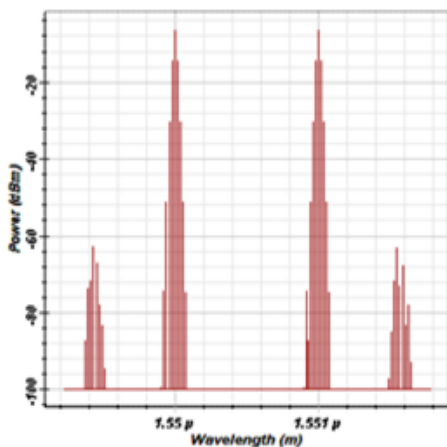

Fig. 3(a) Optical spectrum at the output of fiber when two wavelengths are transmitted

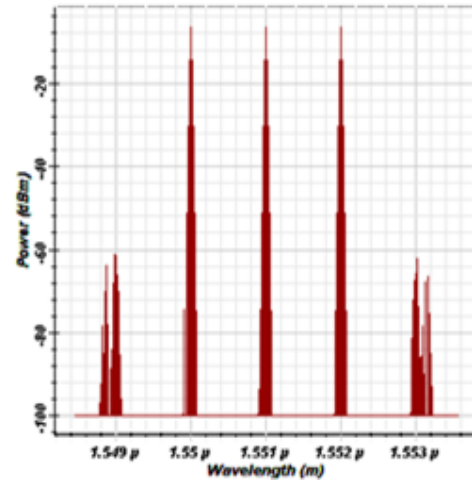

Fig. 3(b) Optical spectrum at the output of fiber when three wavelengths are transmitted

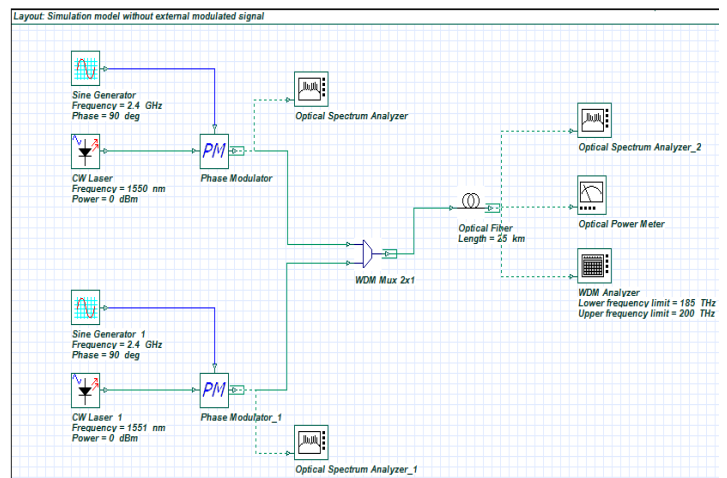

Fig. 4 Simulation setup for WDM PON architecture for transmitters of two wavelengths in Optisystem software

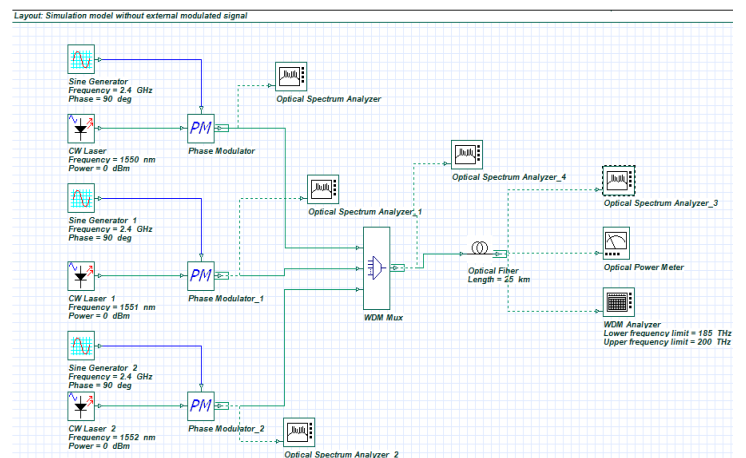

Fig. 5 Simulation setup for WDM PON architecture for transmitters of three wavelengths in Optisystem software

### III. RESULT AND ANALYSIS

The performance of WDM PON is analyzed using the *OptiSystem 7.0* software. The results obtained for the three cases has been described below:

#### A. Effect of Channel Spacing Variation

The channel spacing is increased from 0.1 nm to 1 nm. When the spacing is 0.1 nm with two input wavelengths as 1550 nm and 1550.1 nm, fig. 6(a) shows the signal at the input of the optical fiber. The interfering wavelengths generated are 1549.9 nm and 1550.2 nm, as shown in Fig. 6(b) whose power is approximately -58 dBm. Fig. 7(a) shows the spectrum at the input of fiber for 0.5 nm spacing and Fig. 7(b) shows output with each sideband of power -64 dBm. When the channel spacing is 0.5 nm in Fig 8(a), the power of the FWM sideband is approximately -68 dBm as shown in Fig 8(b). Therefore, the sideband power falls with the increase in channel spacing and hence the effect of the FWM is decreased.

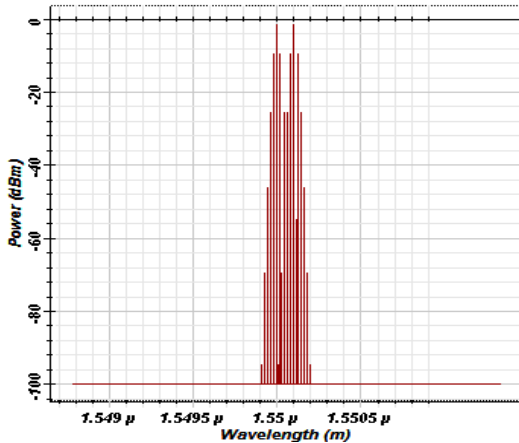

Fig. 6(a) Optical spectrum at the input of fiber when the channel Spacing is set at 0.1 nm

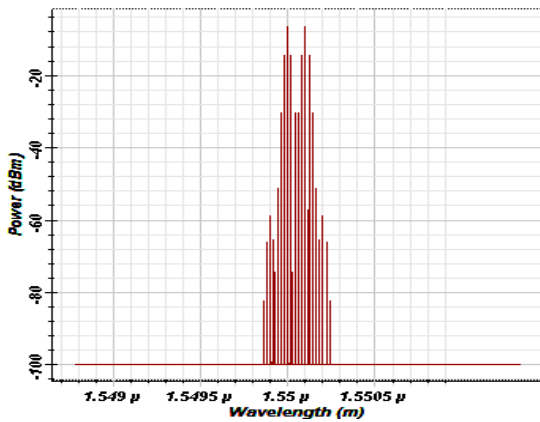

Fig. 6(b) Optical spectrum at the output of fiber when the channel Spacing is set at 0.1 nm

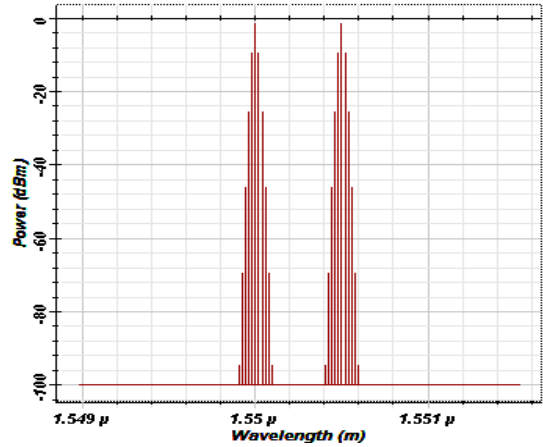

Fig. 7(a) Optical spectrum at the input of fiber when the channel spacing is set at 0.5 nm

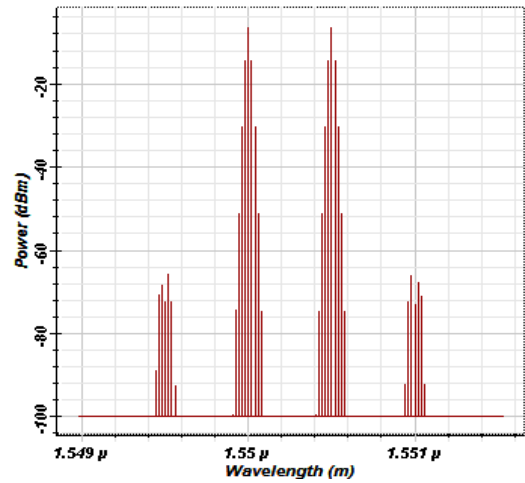

Fig. 7(b) Optical spectrum at the output of fiber when the channel Spacing is set at 0.5 nm

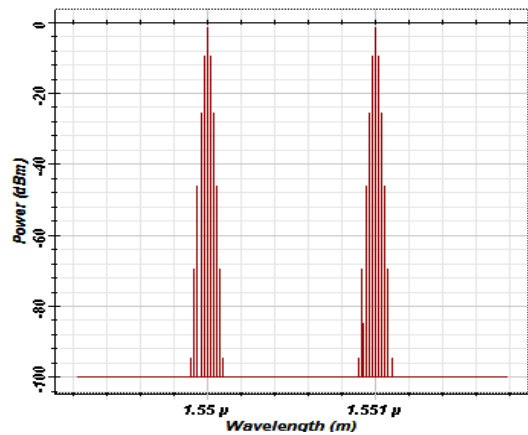

Fig. 8(a) Optical spectrum at the input of fiber when the channel Spacing is set at 1 nm

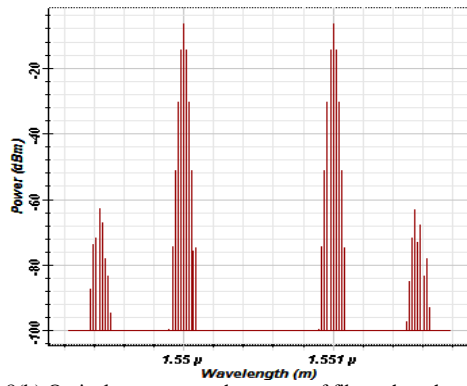

Fig. 8(b) Optical spectrum at the output of fiber when the channel spacing is set at 1 nm

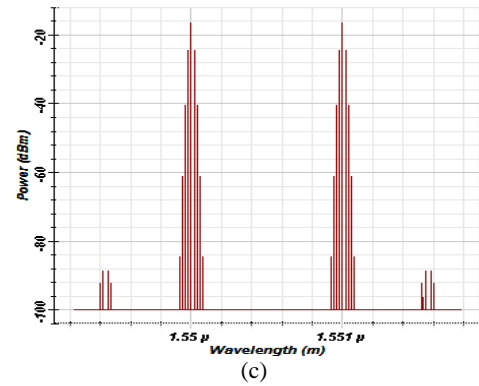

Fig. 9 Optical spectrum at the output of the fiber when input power is set at (a) 20 dBm (b) 10 dBm (c) -10 dBm

**B. Effect of Different Power Levels of the Signal Sources**

For a communication system, it is necessary that the transmitted electromagnetic (EM) wave reaches at the receiver end with sufficient power so as to differentiate the original wave from the background noise. Another parameter to describe strength of signal is the S/N ratio which defines the power of the original signal in comparison to the background noise power. Higher the S/N ratio, the better is the signal.

Here, the power level of the input sources is changed while other parameters such as the channel spacing and the dispersion were kept unchanged. The simulation output when the power at input source is 20dBm is shown in Fig. 9(a). Result for the input source power 10 dBm is shown in Fig. 9(b) and the result obtained for -10 dBm is shown in Fig. 9(c). Therefore, when the power level of the signal sources is decreased FWM effect becomes less.

**C. Effect of Variation in Dispersion of the Fiber Optic**

Wavelength dispersion is a signal dispersion which occurs mostly in single-mode fiber. Here, some amount of light given at input of the fiber gets seeped into the cladding which is wavelength dependent and hence affects the transmission speed. To see the effect on WDM network, the dispersion of fiber is varied from 1ps/nm/km to 16.75ps/nm/km. The Simulation result at dispersion of 1 ps/nm/km is shown in Fig. 10(a), where the sideband power is observed as -63 dBm. When the fiber dispersion is set to 16.75ps/nm/km, the power level of new interfering wavelength generated decreases to -71 dBm as shown in Fig. 10(b). Therefore, when the dispersion parameter is increased, then with the decrease in power level, the FWM effect reduces.

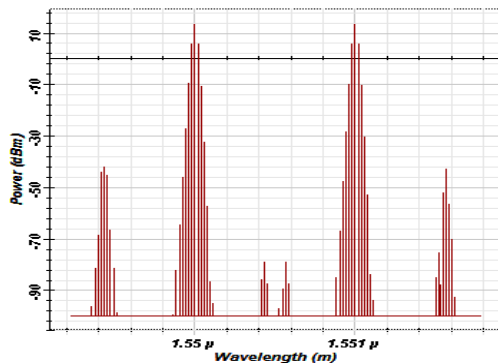

(a)

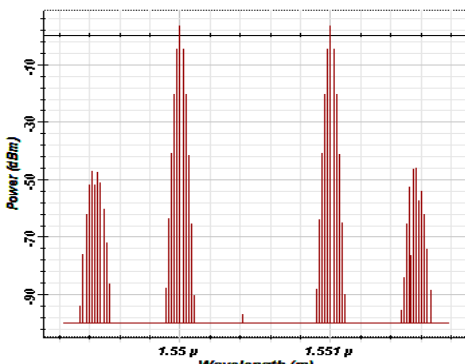

(b)

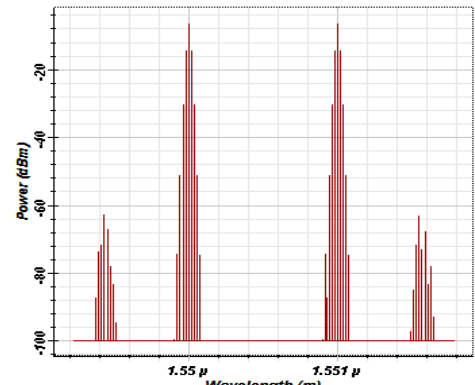

(a)

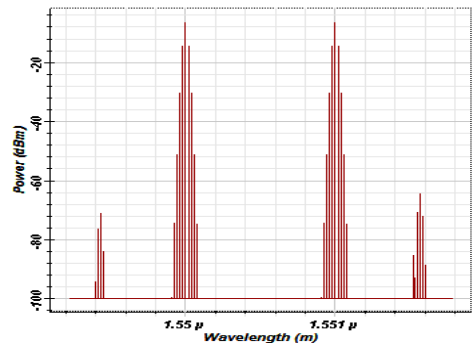

(b)

Fig. 10 Optical spectrum at the output of the fiber when dispersion of fiber is set at (a) 1 ps/nm/km (b) 16.75 ps/nm/km

## IV. CONCLUSIONS

In this paper, WDM in RoF networks are investigated. We have analyzed the performance of network for WDM network without use of any external modulation under the effect of FWM nonlinearity. It has been observed that due to decrease in power level of the signal source, the FWM effect becomes nominal. Also, when the spacing between channels and dispersion parameter is increased, FWM effect decreases. It could be concluded that results obtained from this study will provide useful information for recognizing the limit of the WDM systems capability and the effect of FWM nonlinearity effect can be further reduced in the WDM networks.

## ACKNOWLEDGMENT

I would like to thank my guide, Dr. Brintha Therese A. for her enormous support, inspiration and enthusiasm during the working span.

## REFERENCES

- i. D. Marcuse, "Effect of fiber nonlinearity on long-distance transmission," *Journal of lightwave technology*, vol. 9, pp. 121-128, January 1991
- ii. A Panda, D.P. Mishra, "Nonlinear Effect of Four Wave Mixing For WDM in Radio-over-Fiber", *Quest Journals, Journal of Electronics and Communication Engineering Research*, 2014
- iii. S. Betti, M. Giaconi, and M. Nardini, "Effect of Four-Wave Mixing on WDM Optical Systems: A Statistical Analysis", *Photonics Technology Letters*, 15(8) (2003) 1079 – 1081.
- iv. A.V. Yulin, D.V., and P.St.J. Russell, "Four-wave mixing of linear waves and solitons in fibers with higher-order dispersion," *Journal of lightwave technology*, vol. 29, pp. 950-955, March 2004
- v. Ooi. Sock, "Four wave mixing nonlinearity effect in wavelength division multiplexing system for radio over fiber," *Bachelor thesis, University Technology Malaysia*, 2007
- vi. A Lamminpää, "Measurement of nonlinearity of optical fiber," *Master Thesis, Helsinki University of Technology*, 2003
- vii. A. No'oma, "Radio over fiber technology for broadband wireless communication systems," *Master thesis, Eindhoven University of Technology*, 2005
- viii. A.V. Ramprasad, and M. Meenakshi, "Four wave mixing on dense wavelength division multiplexing optical system," *Academic Open Internet Journal*, vol. 17, pp. 1-8, January 2006
- ix. M. Goloubkoff, "I outdoor and indoor applications for broadband local loop with fiber supported mm-wave radio Systems," *IEEE* 1997, pp. 31-34
- x. Govind P. Agrawal, "Fiber-Optic communication system" McGraw- Hill December 2001
- xi. M. J. Ablowitz, G. Biondini, "Four wave mixing wavelength division Multiplexed soliton systems: ideal fibers", *Journal of Optical. Soc. Am.* 14 (7) (1997) 1788 – 1794
- xii. A.M.J. Koonen, M. Garcia Larrode, "Perspectives of Radio over Fiber Technologies," *Journal of Optical Fiber Communication (OSA)*, 2008
- xiii. A. Bahrami1, "Performance Evaluation of Radio over Fiber Systems Using Mach-Zehnder Modulator", *IEEE Journal on Selected Areas in Communications*, 2008
- xiv. Kwansoo Lee, "Radio over Fiber for Beyond 3G", *IEEE*, July 2005.