

Design & Analysis of Ø40” x 80” Conventional Sugar mill head stock.

Santosh Y Salunkhe

Department of Sugar Engineering, Walchandnagar Industries Ltd,
Walchandnagar, Pune, Maharashtra (INDIA)

Email: sysalunkhe@walchand.com, sysalunkhe9@rediffmail.com

Abstract: Sugar mill head stock play a significant role in the sugar plant as they have to sustain the forces experienced by the rollers while extracting juice from the cane. The present analysis related to modification in sugar mill head stock Ø40”X80”. This paper describes the advantages of using Ø40”X80” mill head stocks by designing & analysis by ANSYS software.

In this study theoretical study has been done considering the Bending moment & force polygon diagrams. Bending moment factor which helps in finding actual results. By changing various parameters the performance of mill head stocks is studied using static structural analysis & the same are compared with above theoretical results. Based on results the optimum design is proposed. ANSYS software is used to calculate principal stresses, deformation of mill head stock.

Keywords- Sugar mill head stock, Modulus of sections, bending moment, Bending stresses, ANSYS.

I. Introduction

Sugar cane is a grass of the genus *Saccharum* which is grown throughout tropical and subtropical regions, producing approximately 4000 lakh metric tons of raw sugar worldwide. The three roller mills are used for extraction of juice which consists of three rollers i.e. Top, Feed and Discharge rollers. These rollers are carried on massive shafts running in their bearing placed in pair of headstocks or housing, which are bolted on a bed plate. These three rollers are housed in a heavy cast steel frame known as “Mill Head stock” or “Mill housing”.

Sugar mill head stocks support bearings in which rollers rotate at various speeds. The size of the head stocks is important as they have to carry the forces experienced by the rollers for varying capacities. In the Factory sugar cane are tipped on the elevator which takes them to the cane crushing mill where the juice is squeezed out. The cane mill consists of two parts: the crushing rollers & squeezing rollers.

The crushing rollers are sometimes preceded by revolving knives. The crushing rollers are arranged in pairs and the squeezing rollers in three-one at top and two at bottom. The three rollers of a mill are fixed relative to each other and their positions in the housing are adjusted at the start of the season.

The squeezing rollers are grooved to grip the cane and to allow passage ways to juice.

The bearing which carry the rollers are able to slide and the rollers are pressed together by hydraulic pressure so that each top roller exerts through pressure on the lower roller. The pressure developed during milling depends on the layer of bagasse. Generally in sugar plant sugar cane passes from first mill to last mill to facilitate maximum extraction of juice from bagasse. In larger mills the total pressure will be distributed over a large area of the bagasse.

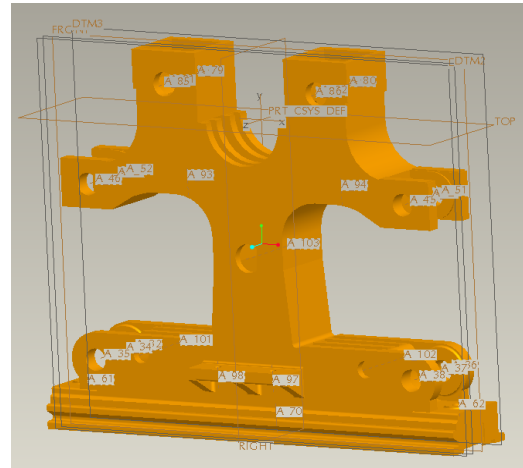

Figure.1. View of Sugar mill Head stock

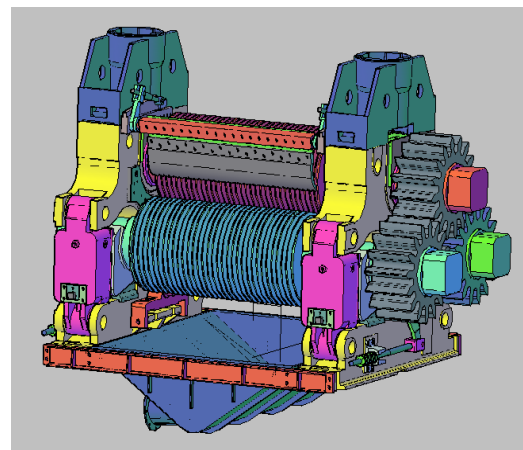

Figure2. Conventional Three Roller mill Assembly. Structural integrity of mill head stock is highly desirable as they play an important role in the sugar industry. The finite element method is a powerful tool to furnish an accurate

solution to a large class of engineering structural problems, involving considerable geometric complexity and various load types. However finite element models of various levels of sophistication depend on the requirement of the problem under consideration. The accuracy of a relative good Finite Element model should be validated with the experimental values. Upon satisfaction the model can be used for further design development with confidence.

Considering the above three roller mill can be the best option because it required trash plate. Hydraulic load is transferred & distributed to the Mill head stock in different section, which has been shown in the figure.no.3. Three rollers has better drainage because of its high extraction efficiency & less juice absorption by bagasse, easy operation & maintance, simple horizontal adjustment of mill setting, large bearing journals which facilitate acceptance of high mill loads. Therefore in sugar industry it is very essential to design three roller conventional mills as it has got above advantages.

In this paper sugar mill head stocks of size Ø40”X80” have been analyzed by calculate modulus of sections with bending moments for various sections with using force polygon diagrams. The ANSYS software is used for the determination of stress levels in the head stocks.

II. Methodology (Theoretical Analysis)

The Ø40”X80 mill stock is of high grade cast steel (IS: 1030, Gr-280-520W) having uniform wall thickness and directly bolted to the foundation. This is of pin type design fitted with wearing plates having efficient lubricating arrangement for the bearing sides of the top roller. The new design permits wider range of operating roller diameters. In this study mill head stock is chosen for Crushing capacity of sugar plant is 7500TCD.

Input data of the mill head stock are as follows:-

Capacity of plant =7500TCD (340TCH)

Mill roller Diameter = 1016 mm. (Ø40”)

Mill roller length = 2032mm (80”)

Design pressure = 280kg/cm².

Ram diameter = 400mm.

Design maximum pressure = 300kg/cm².

Max. Design load = 380 Tons.

Therefore, total hydraulic load is = 380 Tons.

As per the E-Hugot, assuming maximum feed to discharge Opening is 5:1.

Following are the forces acting on the Mill head stock.

- i) Total Vertical Force = 380 Tons.
- ii) Trash plate reaction = 95 Tons.
- iii) Discharge roller reaction = 305Tons.

- iv) Feed roller reaction = 62 Tons.
- v) Apex Angle of mil = 78°.

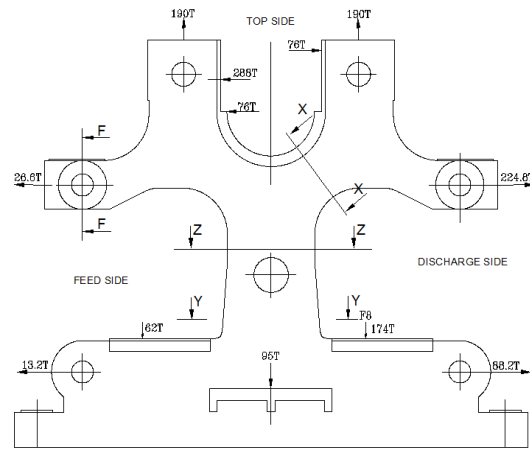

Figure 3. Mill head stock with load details.

Modulus of sections of mill head stock: - refer figure no.3

- a) Section @ XX = $\frac{1}{12} \frac{[56 \times (38.0)^3 - [41 \times (24.0)^3]}{(38.0/2)}$
= 10991.43 cm³.
- b) Section @ YY = $\frac{1}{12} \frac{[53 \times (65)^3] - [41 \times (53)^3]}{(65/2)}$
= 21669.66 cm³.
- c) Section @ ZZ = $\frac{1}{12} \frac{[52 \times (57)^3] - [41 \times (45)^3]}{(57/2)}$
= 17775.15 cm³.
- d) Section @ FF = $\frac{1}{12} [9 \times (32)^3 \times 2]$
= 3072.00 cm³.

Cross Sectional Areas: - refer figure no.3

- a) Section @ XX = $[(56 \times 38.5) - (41 \times 24.0)]$
= 1172.00 cm²
- b) Section @ YY = $[(65 \times 53) - (53 \times 41)]$
= 1272.00 cm².
- c) Section @ ZZ = $[(57 \times 53) - (45 \times 41)]$
= 1176.00 cm².
- d) Section @ FF = $[9 \times 32] \times 2$
= 576.00 cm².

Bending Moments: - refer figure no.3

- i) BM @t section XX (Feed Side) =
= $(288 \times 61.7) - (26.6 \times 7) - (190 \times 28)$
= 12263 Tons cm.
- ii) BM @ section XX (Discharge Side) =
= $(190 \times 28) - (224.8 \times 7)$
= 3746.4 Tons cm

iii) BM @ section YY (Due to thrust 288 tons) =
= 288 x 165
= 47520 Tons cm

iv) BM at section ZZ (Due to thrust 288 Tons) =
= 288x 80
= 23040 Tons cm

Now, Bending Stresses @ above sections:-

- i) Fb @ section XX (Feed side) = 1136.57 kg/cm².
- ii) Fb @ section XX (Disc. side) = 347 kg/cm².
- iii) Fb @ section YY = 1810 kg/cm².
- iv) Fb @ section ZZ = 1296 kg/cm².

Bending Moments: - refer figure no.3

For Section-ZZ:-

Bending Moment @ ZZ due to side cover loads =
= 6336 Tons.cm.
Bending stress @ ZZ = 356 kg/cm².

Total Bending stress @ ZZ = 910.00kg/cm².

For section-YY:-

Bending Moment @ YY due to side cover load=
= 19946 Tons.cm
Direct stress due to Top in load C.S. area @ YY=
= 1378 cm².
Direct stress @ YY = 275.7 kg/cm²
Bending stress @ YY = 844 kg/cm².
Total stress @ YY = 1119.7 kg/cm².

Resultant Bending Stress @ YY = 661.30 kg/cm²

For section-XX:-

Bending stress @ Discharge side = 328.57 kg/cm².
Direct Load Disc. Side @ XX = 263.36kg/ cm².

Total Tensile Stress max. @ XX = 1473.57 kg/cm².
Direct stress on section @ FF = 792.00 kg/cm².

Table 1 Details of modulus of sections & stresses.

Section	Area in cm ²	Modulus of sections in cm ²	Max. stress in Kg/cm ²	Factor of safety as per IS:1030, Gr.280-520W
XX	1172.00	10991.43	1473.57	3.5
YY	1272.00	21669.66	661.30	7.8
ZZ	1176.00	17775.15	910.00	5.7
FF	576.00	3072.00	792.00	6.5

III. Results

The mill head stock is analysed theoretically as well as with the help of ANSYS software for his safe working by checking various parameters within limit & following are the results in ANSYS (Workbench) software.

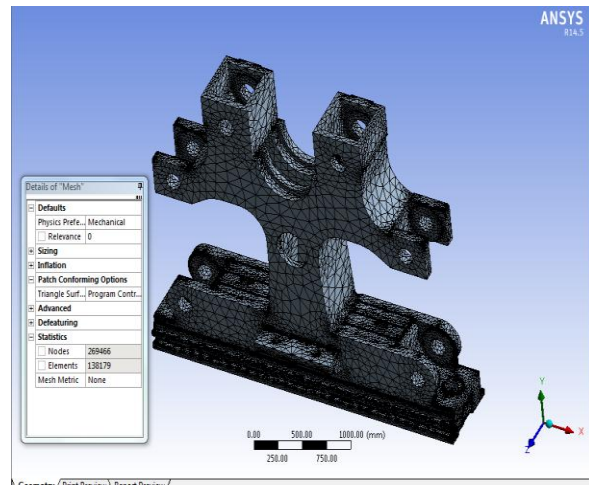

Figure 4. Mesh detail of Mill head stock.

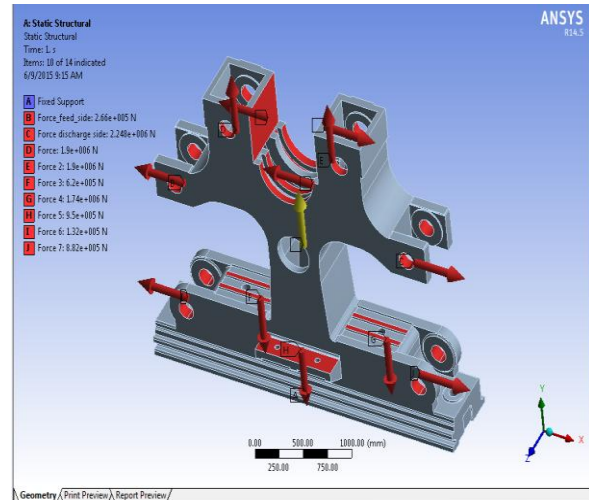

Figure 5. Static structural Mill head stock with load details

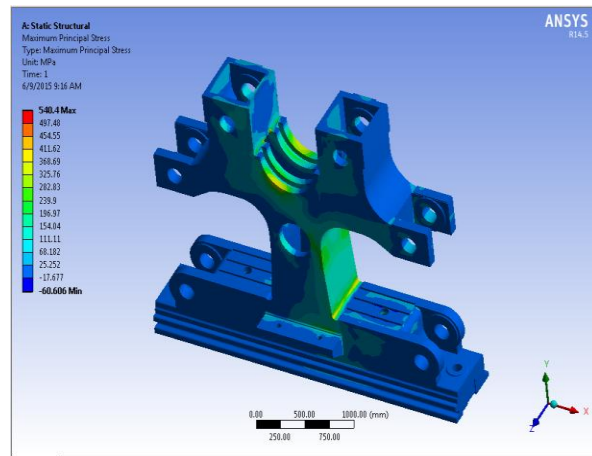

Figure 6. Principle stress in Mill head stock.

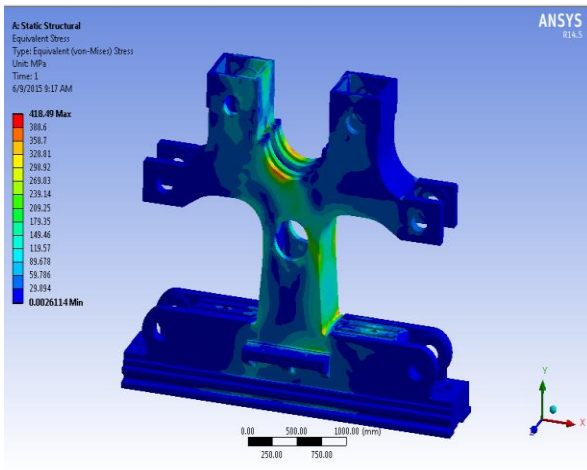

Figure 7. Von-mises stress in Mill head stock

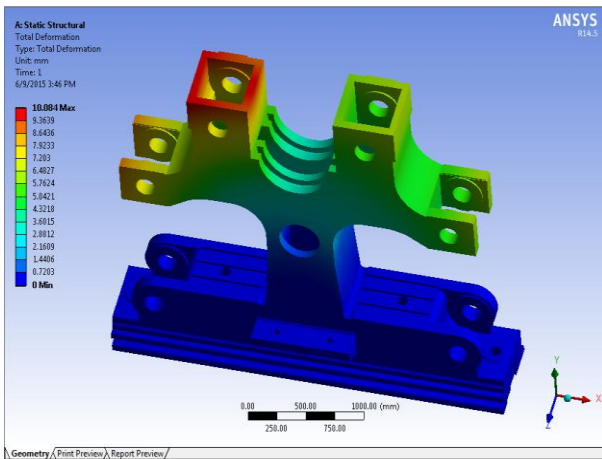

Figure8. Total deformation of Mill head stock

IV. Conclusion

There is a general arrangement of above results. The stress values calculated theoretically as well as ANSYS is nearer and that too much less than the principle & tensile stress value. From above results & mill head stock parameters is safe. Therefore the conventional sugar mill head stock is suitable for Dia. 40”x80” mill size.

Acknowledgement

I would like to thank Mr.D.C.Patil, Sr.G.M. & Mr. S.M.Kulkarni sugar engineering dept. at Walchandnagar industries ltd, Walchandnagar, for their constant encouragement and support for this work.

References

- i) *Experimental and Analytical Analysis of sugar mill head stock*, 1998, pp 61-70.
- ii) *Design analysis of two roller sugar mill by FEA technique.2012*
- iii) R.H.Renton, “The Four –Roller Mill”, 1964, pp 37-42.
- iv) E-HUGOT, “Cane Sugar Engineering”, 1986, pp. 269-272.
- v) *Sugar Hand Book- Jenkins*
- vi) L.A.Tromp, “Machinery & Equipments of the Cane sugar Factory”, 1946, pp.175 – 185.
- vii) *A text book of machine design by R.S.Khurmi.*
- viii) *Engineering mechanics of solids- Egor Paul popov.*
- ix) J.P.Holmen, *Experimental methods for Engineers* (Mc Graw W –Hill, Tokyo, 1984).
- x) D.P.Kulkarni, “Sugar Manufacturing In India”, pp. 53- 56.