

## Analysis of SVPWM Based Speed Control of Induction Motor Drive with using V/F Control Based 3 Level Inverter

Sujeet Kumar Soni, Anil Gupta

Department of Electrical Engineering, LNCT Bhopal M.P. India.

Email : sjtsoni5@gmail.com

**Abstract**— *The main objective of the paper is to control the speed of an induction machine with scalar control technique. Induction motor (IM) because of its poor dynamic response in comparison to the DC motor drives. A Voltage Source Inverter (VSI), it is possible to control directly the stator flux linkage and the electromagnetic torque by the optimum selection of inverter switching vectors. The scalar control technique (V/F) is used because of simplicity of control algorithm implementation and the response is better and accurate with closed loop slip compensation the modelling of an IM drive employing V/F method with application of Space Vector Pulse Width Modulation (SVPWM) is performed in this article, it is better to understand the V/F method and its difficulties. By using 3-level inverter, ripples in speed and torque will reduce. The reference voltage vector is then realized using a voltage vector modulator. The extensive simulation results are presented based on case studies.*

**Keywords:** Induction Motor, SVPWM, V/F Control, 3-Level Inverter

### I. INTRODUCTION

The history of electrical motors goes back as far as 1820, when Hans Christian Oersted discovered the magnetic effect of an electric current. One year later, Michael Faraday discovered the electromagnetic rotation and built the first primitive D.C. motor. Faraday went on to discover electromagnetic induction in 1831, but it was not until 1883 that Tesla invented the A.C. asynchronous motor [1].

Currently, the main types of electric motors are still the same, DC, AC asynchronous and synchronous, all based on Oersted, Faraday and Tesla's theories. Developed and discovered more than a hundred years ago.

#### A. SCALAR CONTROL:

Scalar control as the name indicates, is due to magnitude variation of the control variables only and disregards the coupling effects in the machine. For example, voltage of a machine can be controlled to control the flux, and the frequency or the slip can be controlled to control the torque. However, flux and torque are also functions of frequency and voltage respectively. In Scalar control both the magnitude and phase alignment of vector variables are controlled. Scalar controlled drives give somewhat inferior performance, but they are easy to implement. Scalar controlled drives have been widely used in industry. However, their importance has diminished recently because of the superior performance of

vector-controlled drives which is demanded in many applications. For improvement of quality many industrial applications require variable speed and constant speed. Several techniques have been developed to control Alternating Current (AC) power. The operation of induction motors in the constant volts per hertz (V/f) mode has been known for many decades, and its principle is well understood. With the introduction of solid state inverters, the constant V/f control became popular.

#### B. V/f Control Principle:

The base speed of the induction motor is directly proportional to the supply frequency and the number of poles of the motor. Since the number of poles is fixed by design, the best way to vary the speed of the induction motor is by varying the supply frequency. The torque developed by the induction motor is directly proportional to the ratio of the applied voltage and the frequency of supply. By varying the voltage and the frequency, but keeping their ratio constant, the torque developed can be kept constant throughout the speed range. This is exactly what V/f control tries to achieve.[12]

Other than the variation in speed, the torque-speed characteristics of the V/f control

Reveal the following:

- The starting current requirement is lower.
  - The stable operating region of the motor is increased. Instead of simply running at its base rated speed (NB), the motor can be run typically from 5% of the synchronous speed (NS) up to the base speed. The torque generated by the motor can be kept constant throughout this region.
  - At base speed, the voltage and frequency reach the rated values. We can drive the motor beyond the base speed by increasing the frequency further. However, the applied voltage cannot be increased beyond the rated voltage. Therefore, only the frequency can be increased, which results in the reduction of torque.
  - The acceleration and deceleration of the motor can be controlled by controlling the change of the supply frequency to the motor with respect to time.
- A wide variety of induction motors are available and are currently in use throughout a range of industrial applications. Single phase induction motors are widely used, due to their simplicity, strength and high performance. They are used in household appliances, such as refrigerators, air conditioners, hermetic

compressors, washing machines, pumps, fans, as well as in some industrial applications. Before the days of power electronics, a limited speed control of IM was achieved by switching the three-stator windings from delta connection to star connection, allowing the voltage at the motor windings to be reduced.

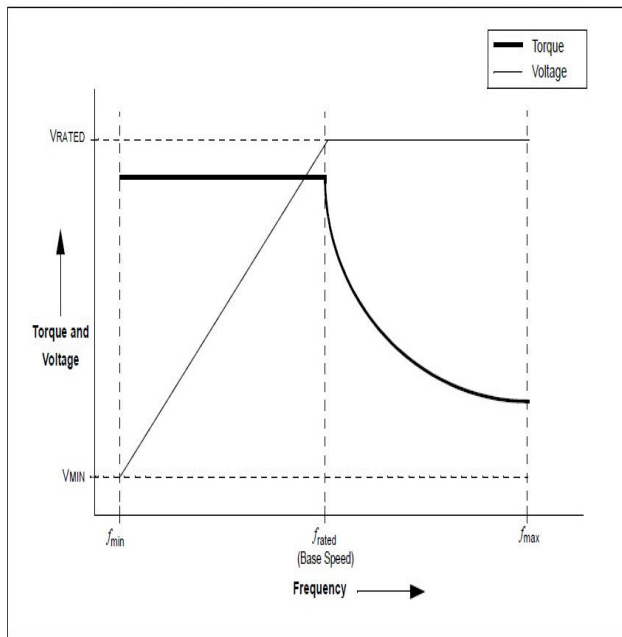

**C. Research Methodology**

The control scheme used has been done in MATLAB. Then accordingly the Results have been obtained after simulation. Suitable development environments are very important in simulation. MATLAB 7.8 has been used for this work. With the MATLAB language, one can program and develop algorithms faster than with traditional languages because it is not needed to perform low-level administrative tasks, such as declaring variables, specifying data types, and allocating memory. The need for ‘loops is also eliminated most of the times in MATLAB. As a result, one line of MATLAB code can often replace several lines of C or C++ code. It’s simple syntax makes it easy to learn and use. It makes debugging faster than any of the programming languages and developing environments. It can also be used as a numerical and symbolic calculator, visualization system, a programming language, modeling and data analysis environment and many more. It allows one to perform numerical calculations, and visualize the results without the need for complicated and time consuming programming. [14].

**II INDUCTION MOTOR MATHEMATICAL MODEL:**

The steady-state model and equivalent circuit are useful for studying the performance of machine in steady state. This implies that all electrical transients are neglected during load changes and stator frequency variations. The Dynamic model of IM is derived by using a two-phase motor in direct and quadrature axes. [13] This approach is desirable because of the conceptual simplicity obtained with the two

sets of the windings, one on the stator and the other on the rotor. The equivalence between the three-phase and two-phase machine models is derived from the simple observation. The concept of power invariance is introduced.[2,3,6] The reference frames are chosen to arbitrary and particular cases such as stationary, rotor, and synchronous reference frames, are simple instances of the general case. The space-pharos model is derived from the dynamic model in direct and quadrature axes.

**A. D-Q MODEL THEORY:**

The assumptions are made to derive the dynamic model as uniform air gap, balanced rotor and stator windings, with sinusoidal distributed mmf, inductance vs. rotor position in sinusoidal, and Saturation and parameter changes are neglected.

Basically, it can be looked on as a transformer with a moving secondary, where the coupling coefficient between the stator and rotor phase change continuously with the change of rotor position. The machine modal can be described by differential equation with time-varying mutual inductance, but such a modal tend to be very complex, note that a three phase machine can be represented by an equivalent two-phase machine in which  $d_r$ - $q_r$  correspond to stator direct and quadrature axes, and  $d_s$ - $q_s$  correspond to rotor direct and quadrature axes. Although it is somewhat simple, the problem of time-varying parameters still remains. R.H. Park in the 1920s, proposed a new theory of electrical machine analysis to solve this problem. The problem has been for mulated with change of variable which, in effect, replaced the variable (voltage, current, and flux linkage) associated with the stator winding of a synchronous machine with variable associated with fictitious winding rotating with the rotor at synchronous speed. Then essentially, transformed, or referred the stator variable to a synchronously rotating reference frame fixed in the rotor. With such a transformation (called park's transformation), all the time varying inductances can be eliminated.[11] Later, in the 1930s, H. C. Stanley showed that time-varying inductances in the voltage equation of machine due to electric circuit in relative motion can be eliminated by transforming the rotor variable to variable associated with fictitious stationary winding, in this case, the rotor variable are transformed to a stationary reference frame fixed on the stator. Later, G. Kron proposed a transformation of a both stator and rotor variable to a synchronously rotating reference frame that move with the rotating magnetic field. D.S. Brereton proposed a transformation of stator variables to a rotating reference frame that is fixed rotor. In fact, it was shown later by Krause and Thomas that time-varying inductance can be eliminated by referring the stator and rotor variable to a common reference frame which may rotate any speed (arbitrary reference frame). Without going deep into the rigor of machine analysis, it will try to develop a dynamic machine model in synchronously rotating and stationary reference frame.

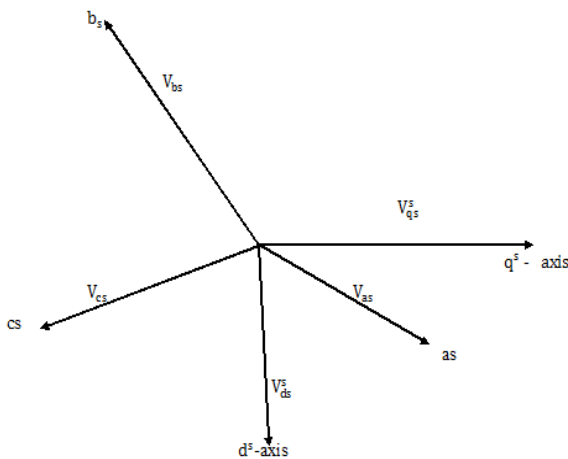

Fig. 2.1 Stationary Frame a-b-c to d<sup>s</sup>-q<sup>s</sup> Axes Transform motion

10

**B. AXES TRANSFORMATION**

Consider a symmetrical three- phase induction machine with stationary by-c a axes at 2π/3 angle apart, as shown in Figure 2.1. The main goal is to transform the three-phase stationary reference frame (a<sub>s</sub>–b<sub>s</sub> – c<sub>s</sub>) variables into two phase stationary reference frame (d<sup>s</sup> – q<sup>s</sup>) variables and then transform these to synchronously rotating reference frame (d<sup>e</sup> – q<sup>e</sup>), and vice versa. Assume that the d<sup>s</sup> – q<sup>s</sup> axes are oriented at 'O' angle shown in Figure 2.1. The voltage V<sub>ds<sup>s</sup></sub> and V<sub>qs<sup>s</sup></sub> can be resolved into as-bs-cs components can be represented in the matrix for m as:

$$\begin{bmatrix} V_{as} \\ V_{bs} \\ V_{cs} \end{bmatrix} = \begin{bmatrix} \cos \theta & \sin \theta & 1 \\ \cos (\theta - 120^\circ) & \sin (\theta - 120^\circ) & 1 \\ \cos (\theta + 120^\circ) & \sin (\theta + 120^\circ) & 1 \end{bmatrix} \begin{bmatrix} V_{qs}^s \\ V_{ds}^s \\ V_{as}^s \end{bmatrix} \quad (2.1)$$

The corresponding inverse relation is :

$$\begin{bmatrix} V_{qs}^s \\ V_{ds}^s \\ V_{as}^s \end{bmatrix} = \frac{2}{3} \begin{bmatrix} \cos \theta & \cos (\theta - 120^\circ) & \cos (\theta + 120^\circ) \\ \sin \theta & \sin (\theta + 120^\circ) & \sin (\theta + 120^\circ) \\ 0.5 & 0.5 & 0.5 \end{bmatrix} \begin{bmatrix} V_{as} \\ V_{bs} \\ V_{cs} \end{bmatrix} \quad (2.2)$$

Where, V<sub>as<sup>s</sup></sub> is added as the zero sequence component, which may or not be present. The voltage had been considered as the variable. The current and flux linkage can be transformed by similar equations. It is convenient to set (1) = 0, so that the q<sup>s</sup>-axis is aligned with the as-axis. Ignoring the zero sequence components, the transformation relations can be simplified with the help of equations (2.1) and (2.2) by assuming (θ) = 0 in these respective equations as:

$$V_{as} = V_{as} \quad (2.3)$$

$$V_{bs} = -\frac{1}{2} V_{qs}^s - \frac{\sqrt{3}}{2} V_{ds}^s \quad (2.4)$$

$$V_{cs} = -\frac{1}{2} V_{qs}^s + \frac{\sqrt{3}}{2} V_{ds}^s \quad (2.5)$$

and inverse equations are expressed as:

$$V_{qs}^s = \frac{2}{3} V_{as} - \frac{1}{3} V_{bs} - \frac{1}{3} V_{cs} = V_{as} \quad (2.6)$$

$$V_{ds}^s = -\frac{1}{\sqrt{3}} V_{bs} + \frac{1}{\sqrt{3}} V_{cs}$$

**III Mathematical Model of Induction Motor**

An induction motor is modeled using voltage and flux equations which are referred to synchronous reference frame, denoted by the superscript "e".

Stator Voltage Equation :

$$V_s^e = R_s i_s^e + j\omega_e \lambda_s^e + P \lambda_s^e \quad (2.7)$$

Rotor Voltage Equation:

$$0 = R_r i_r^e + j(\omega_e - \omega_r) \lambda_r^e + P \lambda_r^e \quad (2.8)$$

Stator Flux Equation :

$$\lambda_s^e = L_s i_s^e + L_m i_r^e \quad (2.9)$$

Rotor Flux Equation:

$$\lambda_r^e = L_r i_r^e + L_m i_s^e \quad (2.10)$$

Mechanical Equation:

$$T_e - T_L = J_m P \omega_r + B_m \omega_r \quad (2.11)$$

$$T_e = \frac{3P}{2} (\lambda_{sd}^e i_{sq}^e - \lambda_{sq}^e i_{sd}^e) \quad (2.12)$$

By referring to a stationary reference frame, denoted by the superscript "s", with d-axis attached on the stator winding of phase "A", the mathematical equations of induction motor can be rewritten as follows.

Stator voltage Equation:

$$V_s^s = R_s i_s^s + P \lambda_s^s \quad (2.13)$$

Rotor voltage Equation:

$$0 = R_r i_r^s - j\omega_r \lambda_r^s + P \lambda_r^s \quad (2.14)$$

Stator Flux Equation:

$$\lambda_s^s = L_s i_s^s + L_m i_r^s \quad (2.15)$$

Rotor Flux Equation:

$$\lambda_r^s = L_r i_r^s + L_m i_s^s \quad (2.16)$$

Mechanical Equation:

$$T_e = \frac{3P}{2} \frac{L_m}{\sigma L_s L_r} (\lambda_{sd}^s i_{sq}^s - \lambda_{sq}^s i_{rd}^s) \quad (2.17)$$

$$T_e - T_L = J_m P \omega_r + B_m \omega_r \quad (2.18)$$

Where σ = total leakage factor,

$$\sigma = 1 - \frac{L_m^2}{L_s L_r}$$

All of the above equations explain the modeling of induction motor in synchronous reference frame and stationary reference frame.

#### IV. Space Vector Pulse Width Modulation (SVPWM):

The space vector pulse width modulation method is an advanced, computation intensive PWM method, which is an excellent feature and is possibly the best among all the PWM techniques for variable frequency drive applications. It has been found wide spread application in recent years, because of its superior performance characteristics.

##### A. Advantages of SVPWM

Space vector PWM is considered a better technique of PWM implementation owing to its associated advantages mentioned below:

Better fundamental output voltage.

Improved harmonic spectrum.

Easier implementation in Digital Signal Processor and Microcontrollers.

##### B. SVPWM For Three-Level Inverter:

This paper proposes a general SVPWM algorithm for three level inverter based on standard two-level inverter. The proposed scheme is described clearly and simulation results are reported to demonstrate its effectiveness. The entire control scheme is implemented with Matlab/Simulink.[04]

Investigated the concepts of sinusoidal pulse width modulation, optimized harmonic stepped waveform and selective harmonic Elimination techniques.[05]

Evaluated the state of the art in pulse width modulations for three-phase voltage source inverter fed AC drives. He described feed forward and feedback pulse width modulation schemes for industrial applications and described the secondary effects such as transients in synchronized pulse width modulation schemes and adequate compensation methods [06]

One of the most popular modulation approaches for two-level converters is space vector pulse width modulation [07], which is now being used more and more in the control of multilevel converters. This is an advanced and computation intensive PWM technique. The SVPWM increases the output capability of SPWM without distorting line to line output voltage waveform. The concept of space voltage vectors corresponding to various switching states has been applied to study the impact of various switching states on the capacitor charge balancing in almost every paper discussing the SVPWM approach. An advantage of the SVPWM is the instantaneous control of switching states and the freedom to select vectors in order to balance the NP. Additionally, one can realize output voltages with almost any average value by using the nearest three vectors, which is the method that results in the best spectral performance .

Zhenyu Yu et. al., [08] described and reviewed the three commonly used PWM techniques, sinusoidal PWM technique, space vector PWM techniques and hysteresis PWM techniques and presented the better utilization of dc supply and reduction of harmonics of space vector PWM vs. sinusoidal PWM

The relationship between the space vector PWM and the carrier-based PWM method, and they proposed a novel carrier-based PWM strategy to balance the neutral point potential and analytically described the voltage.[09]

The proposed new simplified method of space-vector pulse width modulation for three-level inverter based on the simplification of the space-vector diagram of a three-level inverter into that of a two-level inverter[10]

The proposed a space vector PWM algorithm for a three-level voltage-fed inverter, extended to over modulation range. The over modulation strategy easily blends with the under modulation algorithm so that the inverter can operate smoothly from low speed to the extended speed rang.[13]

The three-level space vector PWM inverters and suggests two new algorithms of space vector PWM using non-nearest three and four vectors in a control period to avoid such a narrow pulse problem.[15]

This paper presented a new modulation approach for the complete control of the neutral-point voltage in the three-level three-phase neutral-point-clamped voltage source inverter based on the virtual space vector concept, guarantees the balancing of the neutral-point voltage for any load over the full range of converter output voltage and for all load power factors, the only requirement is that the addition of the output three-phase currents equals zero.[16]

Sinusoidal PWM and space vector modulation techniques used in classical two level industrial inverters. The simulation results are validated by experimental ones obtained employing a NPC inverter prototype and a control board, based on a TI TMS320F2407 microcontroller.[17]

Three-level inverters have attracted the attention of researchers since their introduction by Nabae et al. [18] in 1981. Though simple and elegant, neutral-clamped circuit topology has a few disadvantages. Neutral point fluctuation is commonly encountered as the capacitors connected to DC-bus carry load currents. Also, there is ambiguity regarding the voltage rating of the semiconductor devices, which are connected to the neutral point.

This calls for a conservative selection of devices for reliable operation, which, however, increases cost. H-bridge topology [19, 20] eliminates the problem of neutral fluctuation, but requires three isolated power supplies.

Diode clamped inverter method alleviates the problem but does not eliminate it. Three-Level inversion may also be achieved with two 2-level inverters, driving an open-end winding induction motor from either end [2], [6].

The inverters in this case require isolated power supplies to eliminate the harmonic currents of the triple order in the individual motor phases.

While two level-shifted triangular carrier waves are generally employed to compare the modulating sine wave to generate



PWM signals for a 3-level Inverter [19], one bipolar triangular carrier wave is sufficient for a 2-level inverter, As mentioned earlier, one of the important advantages of the proposed 3-level inverter is that it can be operated as a 2-level inverter in the lower output voltage range. This is accomplished by comparing the modulating sine wave with only one triangular carrier wave for the generation of PWM signals in the lower output voltage range and with two triangular carrier waves in the higher output voltage range. To get a clear picture to facilitate the explanation of the proposed SPWM strategy, the frequency of the triangular carrier wave was chosen to be only 11 times that of the frequency of the modulating sine wave. Also, to simplify the illustration of the concept of the proposed SPWM strategy, it is assumed that the frequency of the modulating sine wave is constant. But, in reality, it is varied by the speed controller as in V/f control or the vector control. Also, the frequency of the triangular carrier wave will be significantly higher in practice. In this paper, a sine-triangle PWM scheme is also proposed for the inverter scheme. The scheme does not require look-up tables to realize the switching sequences as in the case of space vector modulation. Also, the switching criterion that there should be only one switching of the power devices of the constituent inverters during the subinterval of the sampling time period is automatically ensured in the sine-triangle PWM scheme [20]. The salient features of the proposed scheme are:

- A new 3-level voltage source inverter, obtained by cascading two 2-level inverters, is proposed in this paper. The DC link capacitors of individual inverters carry only the ripple currents and not the load current. Hence the voltage fluctuations of the neutral point are avoided in the proposed scheme. However, three switches in the proposed scheme must be rated to block the entire DC bus voltage. In the lower range of output voltage, 2-level inversion can be achieved by switching only one inverter and therefore the switching losses are lower when compared to a conventional 3-level inverter.
- A modified sine-triangle-based PWM is also presented in this paper. The scheme is capable of ensuring a smooth changeover from 2- to 3-level inversion mode and vice versa.
- Simulation results indicate that the proposed inverter scheme is capable of rendering good performance in closed loop applications also.

**C. Three-level Inverter Topology and Switching states**

Fig.1 shows a schematic diagram of a three-level inverter. Each phase of the inverter consists of two clamping diodes, four IGBTs and four freewheeling diodes. Since three kinds of switching states and terminal voltages exist in each phase, the three-level inverter has  $27(3^3)$  switching states. Fig. 3.2 shows the representation of the space voltage vectors for output voltage and the space vector diagram of all switching states, where the P, O, N represent terminal voltage respectively, that is  $V_{dc}/2$ , 0,  $-V_{dc}/2$ . According to the magnitude of the voltage vectors, we divide them into four groups; zero voltage vector (V0), small voltage vectors (V1, V4, V7, V10, V13, and V16), middle voltage vectors (V3, V6,

V9, V12, V15, V18) and large voltage vector (V2, V5, V8, V11, V14, and V17). The zero voltage vector (ZVV) has three switching states, small voltage vector (SVV) has two switching states, the middle voltage vector (MVV) and large Voltage vector (LVV) has only one switching state.

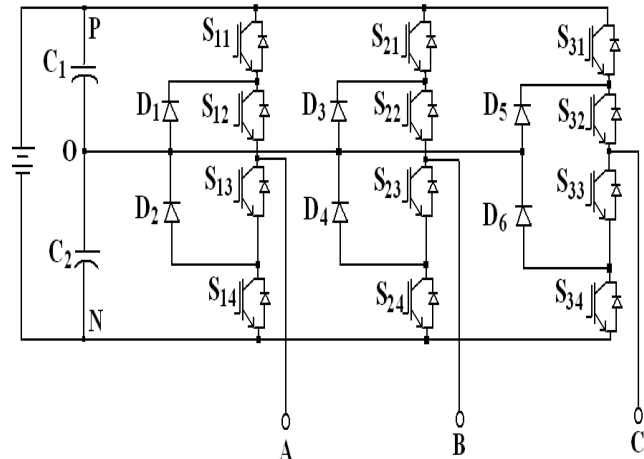

Fig no. 01 : Schematic diagram of three-level inverter

**Switching states of three- level inverter**

Switching symbols	Switching condition				output voltage (Vao)
P	O	O	OF	OF	$+V_{dc}/2$
O	OF	O	O	OF	0
N	OF	OF	O	O	$-V_{dc}/2$

**5. RESULT:**

(i) .when v/f are connected

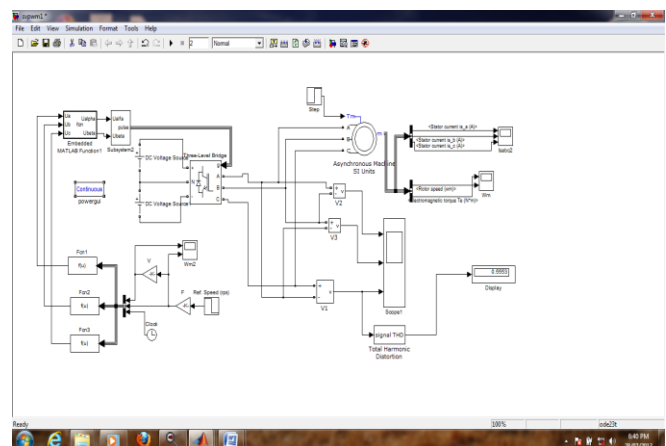
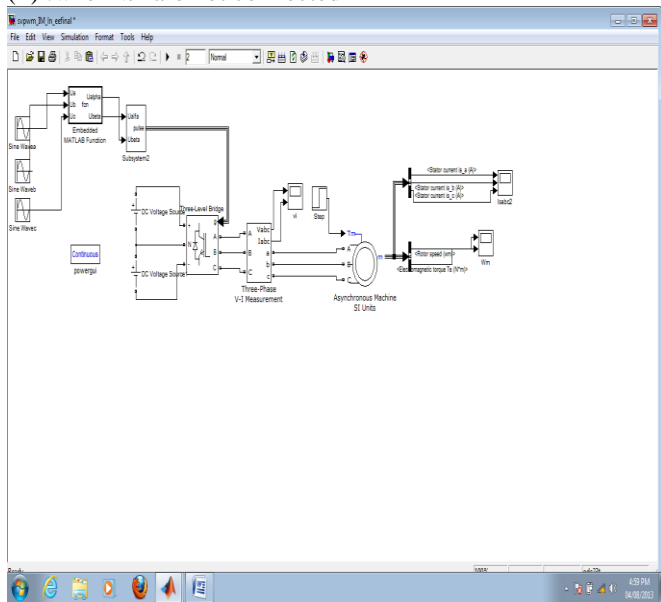

Fig.3.1 : SVPWM based speed control of induction motor v/f control

(ii) .when v/f are not connected



Svpwm based speed control of induction motor

4.RESULT ANALYSIS:

A.1.Changing In Reference Speed:

In this case, reducing the reference speed of induction motor from 157 to 130 rps at t=1 sec. in this case, up to t=3 sec. drive is operated at 130 rps. speed and after t=1 sec. controllers reduce the speed of induction motor to 130 rps. The corresponding speed, dc link voltage and stator currents are showing in Fig. 1

Respectively. According to currents, it seems that motor is operating at constant load at before and after t=1 sec.

2. In this case speed of induction motor are constant when change of load torque.

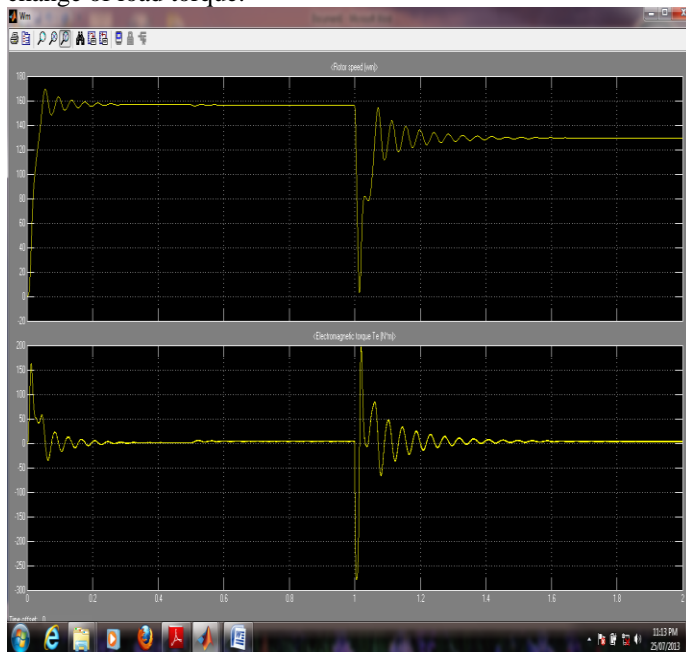

Speed v/s torque

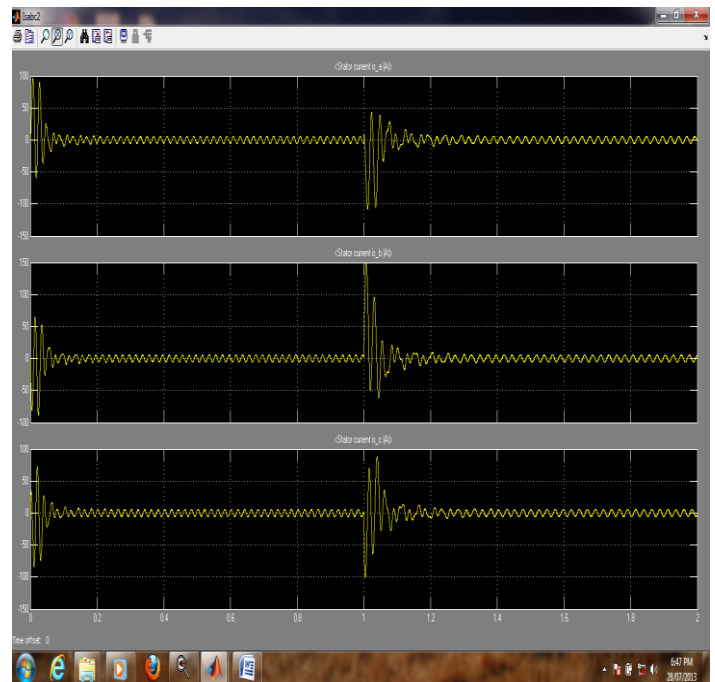

Stator current ia,ib&ic

B. Changing In Reference Speed :

In this case speed of induction motor varies time to time when change of load torque.

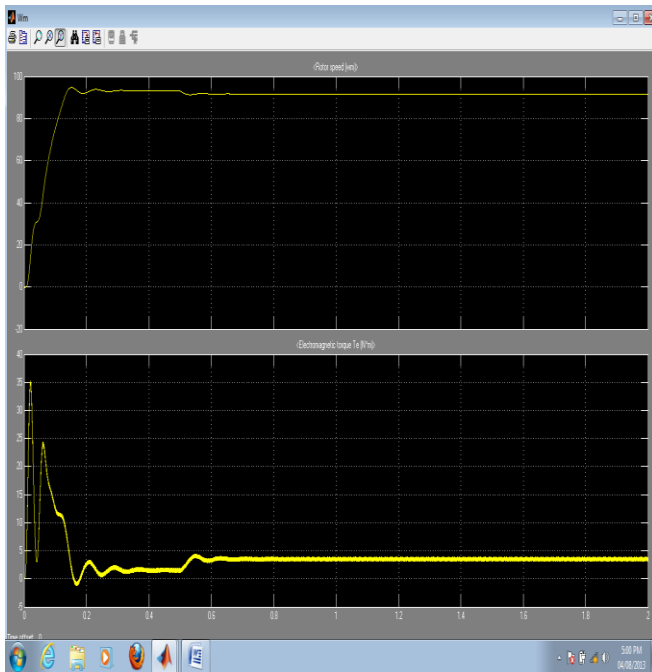

Speed v/s torque

5. CONCLUSION:

The present paper has presented a induction motor drive based on v/f controller. This controller determinates the desired amplitude of torque in terms of voltage and speed in terms of frequency. By using 3-level inverter, ripples in speed and torque will reduce.

The main advantage in this proposed method is incorporated V/F based induction motor control with SVPWM based 3-level inverter. So that the advantages in 3-level with SVPWM as increased the performance and life time of drive. These advantages allow implementing controllers for electric vehicles; because, mainly electric vehicles need high starting torque so this is produce the required torque with minimum torque ripples and in electric vehicles, operation of drive is depends on variable torque with constant speed applications as well as variable speed with constant torque application.

6. REFERENCE:

- i. I.P. Kopylov, *Mathematical Models of Electric Machines*, Translated from the Russian by P.S. Ivanovo, Revised from the Russian edition, 1980
- ii. Bose B.K., *Modern power electronics and AC Drives*, Prantice Hall 2002.
- iii. G. K. Dubey, *Power Semiconductor Controlled Drives*, Prentice Hall, Englewood, NJ, 1989
- iv. O.Chandra Sekhar and K.Chandra Sekhar, *Simulation and Comparison of 2-L & 3-L Inverter Fed Induction Motor DTC Drives* International journal of computer and electrical engineering vol.3 No.5 October 2011
- v. P.K.Chaturvedi, Shailendra K. Jain, Pramod Agrawal, "Investigations on Different Multilevel Inverter Control Techniques by Simulation," *IETE Journal of Research*, vo.54, issue 4, 2008, pp. 297-307.
- vi. Joachim Holtz, "Pulse Width Modulation- A Survey," *IEEE Tans. on Industrial Electronics*, vol. 39, No. 5, December 1992, pp.410-420.

- vii. Van Der Brmck, H.W., Skudelny, H.C. and Stanke G.V., "Analysis and Realization of a Pulsewidth modulation based voltage space vectors", *IEEE Transactions on Industry Applications*, Vol. 24, No. 1, January1988, pp. 142 -150.
- viii. Zhenyu Yu, Arefeen Mohammed, Issa Panache, " A Review of Three PWM Techniques," *Proceedings of the American Control Conference*, New Mexico, June 1997, pp. 257-261.
- ix. Jang-Hawan Kim, Seung-Ki Sul, "Carrier based Pulse Width Modulation for Three-level Inverters: Neutral point potential and Output Voltage.
- x. Jae Hyeong Seo, Chang Ho Choi, Dong Seok Hyun, "A new simplified space-vector PWM method for three-level inverters," *IEEE Trans. Power Electronics*. Vol. 16, July 2001, pp.545-550.
- xi. R. H. Park, *Two-reaction theory of synchronous machines-generalized method of analysis -Part 1*, *AIEE Trans.*, vol. 48, pp. 716-727, July 1929
- xii. [www.renesas.com](http://www.renesas.com)
- xiii. Subrata K. Mondal, Joao O. P. Pinto, and Bimal K. Bose, "A Neural-Network-Based Space-Vector PWM Controller for a Three-Level Voltage-Fed Inverter Induction Motor Drive", *IEEE Trans. On Industry Applications*, vol. 38, no. 3, May 2002, pp. 660-669.
- xiv. [www.mathworks.com](http://www.mathworks.com)
- xv. H. L. Liu, and G. H. Cho, "Three-Level Space Vector PWM in Low Index Modulation Region Avoiding Narrow Pulse Problem", *IEEE Transactions On Power Electronics*, Vol. 9, No. 5, September 1994, pp. 481-486.
- xvi. S. Busquets Monge, J. Bordonau, D. Boroyevich, and S. Somavilla, "The Nearest Three Virtual Space Vector PWM—A Modulation for the Comprehensive Neutral-Point Balancing in the Three-Level NPC Inverter", *IEEE Power Electronics Letters*, Vol.2, No.1, March 2004, pp 11-15.
- xvii. Bellini. A, S. Bifaretti, "Comparison between Sinusoidal PWM and Space Vector Modulation Techniques for NPC Inverters", *IEEE Russia Power Tech 2005*, 27-30 June 2005, pp. 1.-7.
- xviii. A. Nabae, I. Takahashi, and H. Agaki, *A new neutral-point-clamped PWM inverter*, *IEEE Trans. IA.17*, pp. 518-523 (1981).
- xix. M. D. Manjrekar and A. Lipo, *A hybrid multilevel inverter topology for drive applications*, *IEEE-APEC- /998*, California, pp. 523-529.
- xxi. A. Rufer, M. Veenstra and K. Gopakumar, *Asymmetric multilevel converter for high resolution voltage phasor generation*, *EPE'99*,